

Scania Diagnos & Programmer 3

User instructions

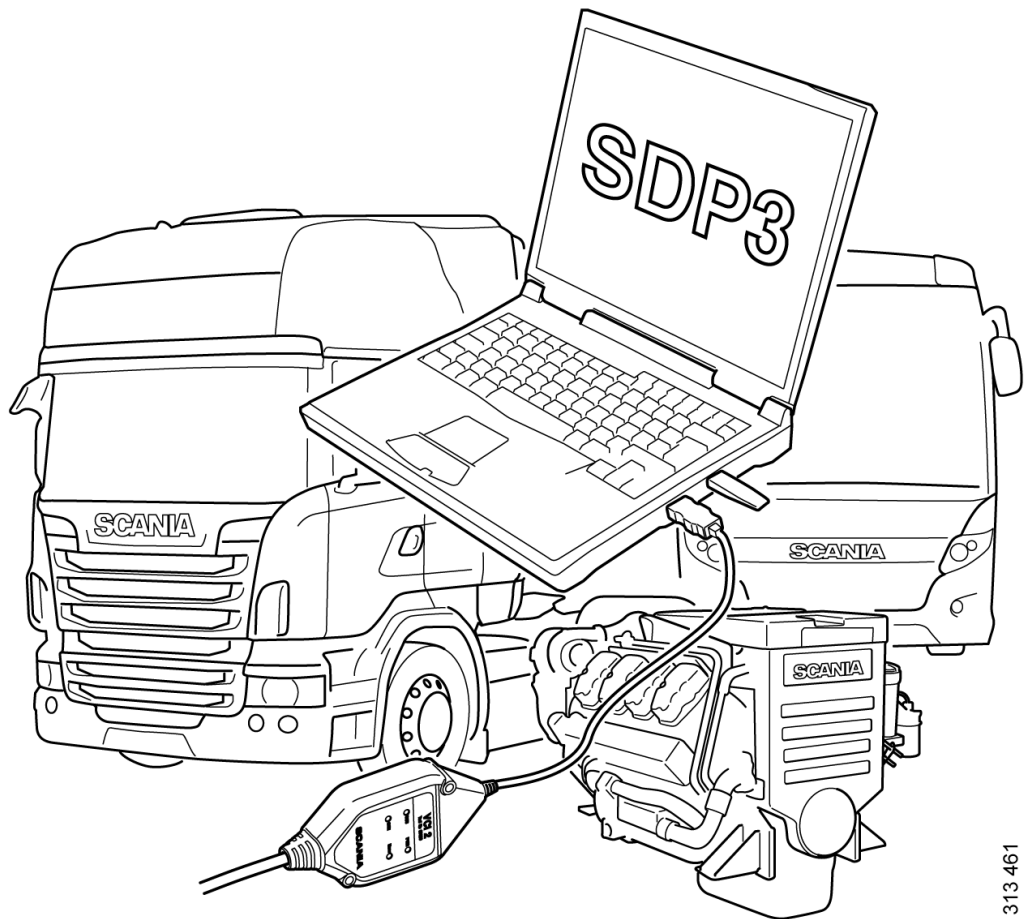

313 461

Contents

Introduction	General	3
	Why SDP3?	4
System requirements and ancillary equipment	System requirements	5
	Ancillary equipment	5
Safety	Test driving the vehicle	12
	Connecting and disconnecting	13
	Adjustment	13
Installation	Installing the program	14
Working with SDP3	About the user instructions	16
	Text display and searching in the text	17
	Starting a task	18
	Checks and adjustments	19
	Conversion	47
	Inspection	56
	ECU update	57
	Bodywork	67
	Connecting	68
	Spare parts programming	70
	Communication	71
	Graphic symbols in the program	72
	Demo mode	76
	Saving and printing vehicle information	78
	Viewing stored operational data	79
Search	80	
Viewing all fault codes	81	
Help	82	
Fault handling	Electromagnetic fields	83
	Reporting faults and queries	83

Introduction

General

Scania Diagnos & Programmer 3 (SDP3) communicates with Scania vehicles and Scania industrial and marine engines. The program has been developed to support the electrical system with CAN communication. The program is used for troubleshooting, adjusting customer parameters, calibrations, conversions affecting the electrical system and updating software in control units.



Why SDP3?

Today's vehicles and especially today's electrical systems with their control units and distributed functions place greater demands on tools and technicians. It is both time-consuming and complicated to carry out troubleshooting on vehicles of such complexity. SDP3 has therefore been designed to support the mechanic during troubleshooting and thus reduce downtime.

SDP3 also supports the troubleshooting of industrial and marine engines.

An advantage of SDP3 is that there are more possibilities than before for the individual item, i.e. the vehicle or engine to which you are connected, to give a description of itself. SDP3 makes use of this and only displays information relevant to the vehicle/engine to which it is connected.

System requirements and ancillary equipment

System requirements

The system requirements applicable to SDP3 can be found on the Technical Information Library website which can be accessed via SAIL.

Ancillary equipment

Use of the program requires a PC, a USB key and a VCI. These components must comply with the applicable system requirements, see System requirements, so that the program will operate correctly.

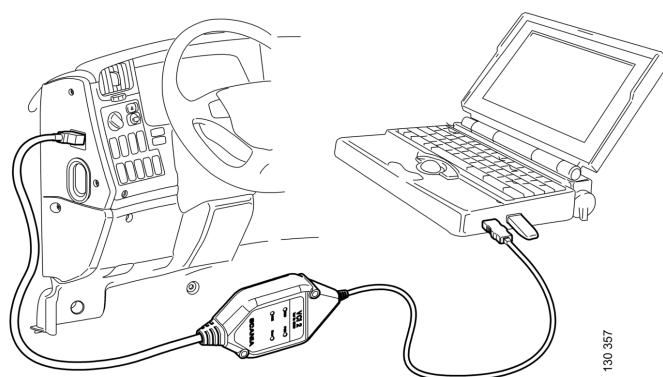

USB key

A USB key supplied by Scania is required. In accordance with the applicable agreements, the USB key is the property of Scania. This means that a stolen or lost USB key should be reported to Scania, where it is entered on a list of blocked IDs. To do this, contact your distributor who will in turn contact Scania.

Distributors can find more information on USB keys in the VCI and USB procedures for external administration. This can be accessed via SAIL under Services/Technical Information/VCI and USB keys tab.

You will find information about the USB key that is used under Settings in the menu. The access levels for the different types of USB keys that may be used are also described here.



Information about the USB key that is currently in use can be obtained under Settings in the menu.

The USB key controls access, i.e. which parts of the program you have access rights to.

A different type of USB key is required depending on whether you will be working on a vehicle or an industrial and marine engine.

If access is shown as BLOCKED, this implies that Scania has entered the USB key in a list of blocked IDs. If access is shown as UNKNOWN, this indicates that the USB key is of a different type to the one approved by Scania.

VCI

The VCI used for SDP3 differ from the VCI used for SD2 and SP2. VCI is the interface that is used between the vehicle or industrial and marine engine and the computer and can be purchased from Scania as a special tool, part number 99 430.

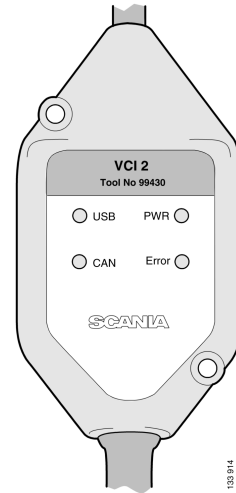

Function of the lamps for VCI2

PWR (green)

The lamp lights up continuously when the VCI2 is supplied with voltage both from the vehicle or I/M engine and the computer. The lamp flashes when the VCI2 is connected to the computer.

USB (yellow)

The lamp lights up (flashes rapidly) when data is transmitted between the computer and VCI2 via the USB key.

CAN (yellow)

The lamp lights up (flashes rapidly) when data is transmitted between the VCI2 and the vehicle or I/M engine via the CAN bus.

Error (red)

The lamp lights up when there is a communication error on the CAN bus.

After connecting VCI to the PC and starting SDP3, you can access information about VCI by opening View in the menu.

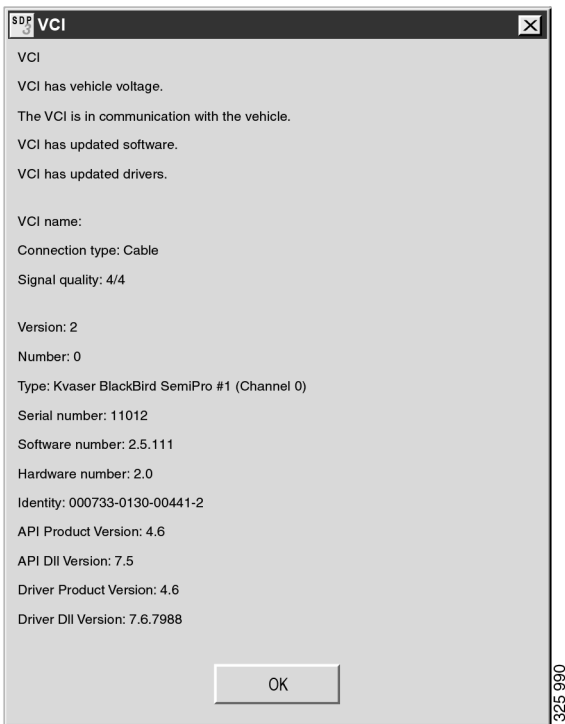

Information about VCI can be accessed under View in the menu.

Adapter for connection on industrial and marine engines with diagnostic socket

On industrial and marine engines, the diagnostic socket is located on the engine. When connecting SDP3, an adapter must be used to be able to connect VCI. The adapter can be ordered from Scania as a spare part, part number 1 862 924.

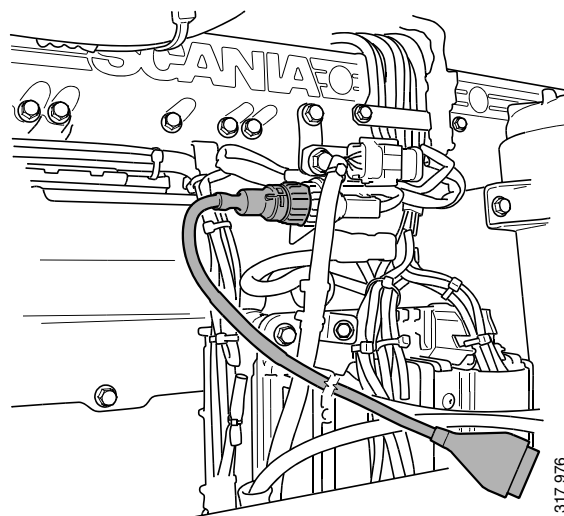

Adapter for connecting VCI. The location of the diagnostic socket on the engine may vary. The illustration is an example.

Adapter for connection on industrial and marine engines without diagnostic socket

An adapter must be used when connecting SDP3 to engine control unit S6 on industrial and marine engines without a diagnostic socket. The adapter can be purchased from Scania as a special tool, part number 99 043. The adapter is used together with VCI.

- 1 Switch
- 2 Connector to engine control unit connection B1
- 3 Connection for engine cable harness B1
- 4 Connection for VCI
- 5 Connection for VCI with four-pin DIN
- 6 Connection for external 24 V power source
- 7 Cables for external power source
- 8 Lamps for battery voltage U30 (red) and for when the starter key is in drive position 15 (green)

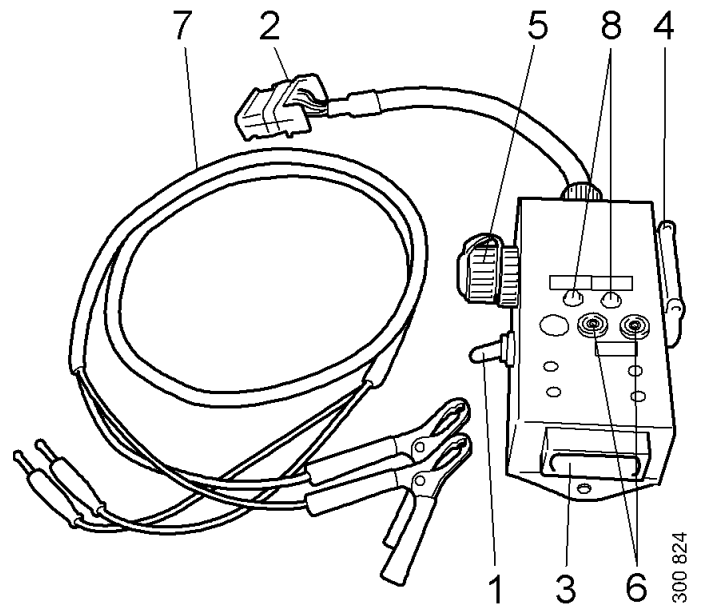

Connection

In order to avoid any risk of a short-circuit:
Make sure that the adapter switch is set to Off
before the adapter is used.

If the engine is connected to other systems:

- Remove the engine control unit connector B1 and fit the adapter connector 2 instead.
- Connect the engine control unit connector B1 to the adapter connector 3.
- Connect the VCI to adapter connection 4 or 5.
- Check that you have battery voltage (red lamp) to the engine and turn the starter key to the drive position 15.

If a diagnosis is to be carried out on the engine without connecting other systems:

- Remove the engine control unit connector B1 and fit the adapter connector 2 instead. Leave the engine control unit connector disconnected.
- Connect the VCI to adapter connection 4 or 5.
- Connect an external 24 V power source to the adapter connections 6 via the cables 7 supplied.
- Set the adapter switch to On so that the green lamp for starter key in drive position 15 lights up.

Safety



IMPORTANT!

Always ensure that a task is carried out so that there is no risk that you or anyone else will be injured.

Test driving the vehicle

Remember that there are some risks if you carry out a test drive when the program is connected. Two persons are required to carry out a test drive: one to drive the vehicle, and one to operate the program. Scania strongly advises against test driving on public highways with the VCI and/or computer connected unless otherwise specified.

Vehicle components can be unexpectedly activated or the engine can stop (causing the loss of power steering).

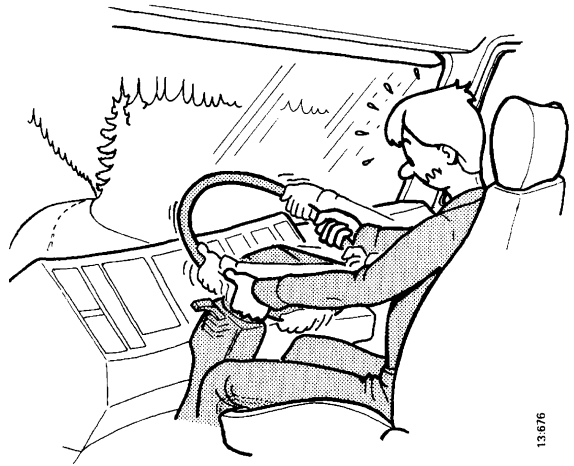

13/676

Connecting and disconnecting

Connection or disconnection of the VCI and/or PC when the vehicle is moving is forbidden.

The vehicle must be stationary when the VCI and/or PC is connected or disconnected. Other instructions for use can be found in the program.

Adjustment

During adjustment, settings in the control units are changed. Some of these changes, or combinations of settings, may have an adverse effect on the characteristics of the vehicle/engine without prior warning. Incorrect use of the software therefore entails a risk of personal injury, damage to property and a breach of the relevant legislation.

Adjustments should therefore only be carried out by personnel who are receiving ongoing training by the Scania organisation on SDP3 and the vehicles and industrial and marine engines concerned, and who are studying the SDP3 user instructions and other service instructions on an ongoing basis.



WARNING!

Adjustment of parameters should only be carried out on stationary vehicles.

Installation

Note: Before the program is distributed, it is virus-checked as comprehensively as possible. Make sure that the computer on which the program is installed is virus-free!

It is necessary to have administrator rights in order to install the SDP3 program.

Installing the program

- 1 Close all active programs except Windows.
- 2 Regardless of whether the file was downloaded from the Internet or comes from a CD, proceed as follows:
- 3 Double-click the program file.
- 4 Installation starts and a number of dialogue boxes will be displayed. Follow the instructions in these dialogue boxes.

In order to ensure that the computer has the correct drivers and software for the USB key and VCI, you must insert them in the computer during installation.

When installation is carried out for the first time, the Windows hardware wizard starts. Work through the hardware wizard and then continue with the installation.

Installing SDP3 may involve several installations and it is only when all these have been carried out that you can use the program correctly.

Clickable shortcuts

Clickable shortcuts placed on the computer desktop after installation:



Start SDP3.

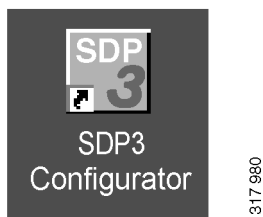

Open SDP3 Configurator to change the language or the logging level.

At installation time, two directories are created which you can also access via shortcuts on the desktop.

- Reports: Saved documents are stored here, e.g. printouts from work in SDP3.
- Log files: Information recorded while working in SDP3 is logged here. This information may be useful for troubleshooting, for example. The logging level can be set in SDP3 Configurator.

Working with SDP3

About the user instructions

This section describes how SDP3 works. Some parts are only suitable for working with a vehicle and a USB key with the highest access levels. This means that if you are working on an industrial and marine engine or have a USB key with limited access levels, not all the sections described are available.

The user instructions take their examples from vehicles. For those sections that are accessible to industrial and marine engines, the instructions still apply even though texts and illustrations are referring to vehicles.

Text display and searching in the text

For some texts it is possible to select how to display the text in SDP3.

At the bottom right of the page there is a zoom function.

It is also possible to select how the text layout should be displayed using three buttons.

There is a search function at the bottom left of the page. When you click on the symbol a text box appears where you can enter the search word and search the text on the page.

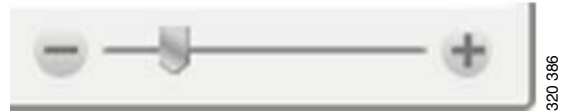

320 386

Zoom function

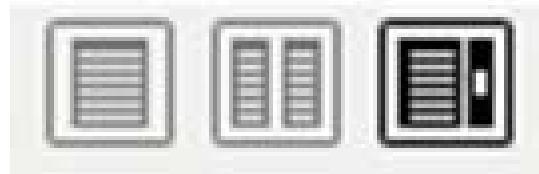

320 388

Selecting the text layout



320 387

Search function

Starting a task

When you have started the program, the start window will be displayed. Select here the type of task you wish to carry out: Checks and adjustments, Conversion, Inspection, ECU update or Bodywork. More information about the relevant work option can be found on the following pages.

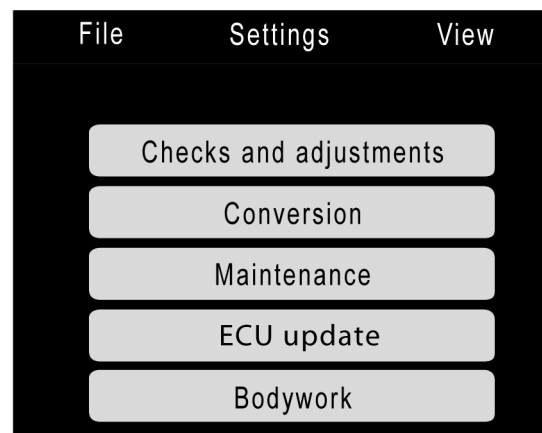

Selecting the work option: Checks and adjustments, Conversion, Inspection, ECU update or Bodywork.

Checks and adjustments

In the Checks and adjustments work option, you can carry out troubleshooting and change adjustable values.

Here you can access information in order to troubleshoot the different control systems and their related components and circuits. There is also an option to troubleshoot via user functions.

You can also reset parameters in the vehicle control units and carry out calibrations and resetting.

Procedure when checking

A suitable procedure for troubleshooting is described here.

Start by finding out what problems the customer has experienced.

- 1 Start SDP3.
- 2 Start the Checks and adjustments work option.
- 3 Go to Electrical system and read the registered fault codes.

All registered fault codes will be displayed under Electrical system.

If there are fault codes connected with the problems which the customer has experienced, continue troubleshooting via Electrical system by checking the circuits concerned and rectify the fault.

Otherwise, you should carry out troubleshooting via User functions. Start by checking that the vehicle has a user function which could be connected with the problem experienced by the customer. Then continue troubleshooting using the information provided under User functions.

Troubleshooting via Electrical system

Under Electrical system, you can troubleshoot in relation to the electrical system. SDP3 communicates with all the vehicle control units at the same time.

You can obtain a description of the electrical system with its related circuits and components. You can read fault codes, read signals, activate components and carry out tests, adjustments and calibrations.

Navigation under Electrical system

Navigation under the Electrical system has the same structure as the vehicle's electrical system.

1 Vehicle

2 System

The vehicle has a number of electronic control systems. The system is the control unit with its components and circuits.

3 Control unit

Information about the control unit's hardware is presented here.

4 Server

Information about the control unit's software is presented here, i.e. the functions which are available in the control unit. Here you can carry out checks related to the control unit, carry out adjustments and calibrations.

5 Component group

The circuits are grouped under each component group according to the main component in the circuit.

6 Circuit

Here you can obtain information in order to troubleshoot the vehicle's electrical circuits.

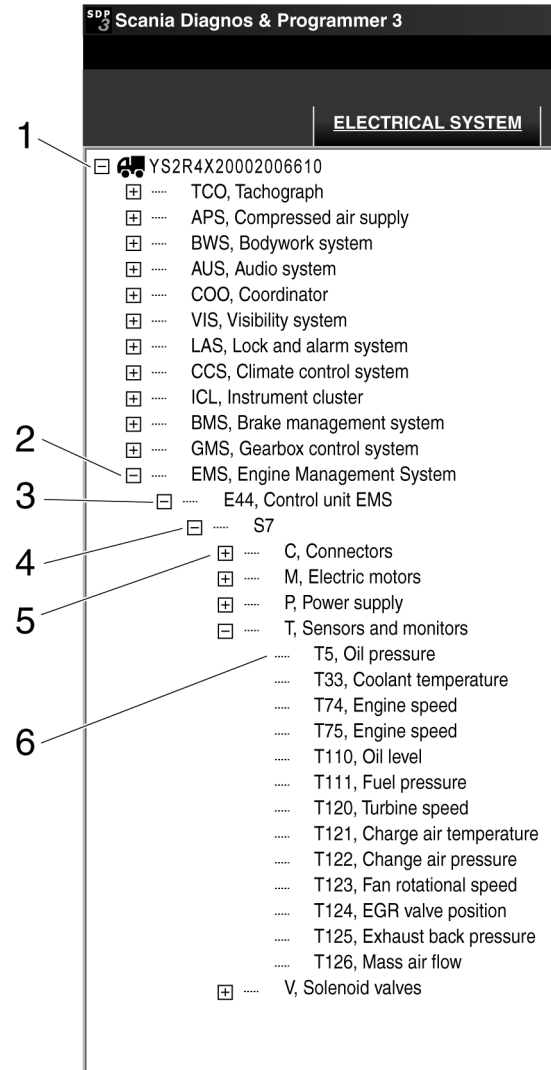

313 464

Levels when navigating under Electrical system.

The content under the different tabs varies, depending on where you are in the navigation tree.

The screenshot shows the Scania Diagnos & Programmer 3 interface. The title bar reads "Scania Diagnos & Programmer 3". Below it, a dark bar contains the text "ELECTRICAL SYSTEM".

On the left, a navigation tree is displayed with the following items:

- 1 [] YS2R8X40002029916
 - [] TCO, Tachograph
 - [] APS, Compressed air supply
 - [] BWS, Bodywork system
 - [] AUS, Audio system
 - [] COO, Coordinator
 - [] VIS, Visibility system
 - [] LAS, Lock and alarm system
 - [] CCS, Climate control system
 - [] ICL, Instrument cluster
 - [] BMS, Brake management system
 - [] GMS, Gearbox control system
 - [] EMS, Engine Management System
 - 2 [] E44, Control unit EMS
 - 3 [] S7
 - 4 [] C, Connectors
 - [] M, Electric motors
 - [] P, Power supply
 - 5 [] T, Sensors and monitors
 - 6 [] T5, Oil pressure
 - [] T33, Coolant temperature
 - [] T74, Engine speed
 - [] T75, Engine speed
 - [] T110, Oil level
 - [] T111, Fuel pressure
 - [] T120, Turbine speed
 - [] T121, Charge air temperature
 - [] T122, Charge air pressure
 - [] T123, Fan rotational speed
 - [] T124, EGR valve position
 - [] T125, Exhaust back pressure
 - [] T126, Mass air flow
 - [] V, Solenoid valves

On the right, a table is displayed with the following columns:

Fault codes	Description	Check	Location	Components	Adjusting
[Empty table content]					

313 465

The table on the following page gives an indication of what sort of information the tabs contain on the different levels. The numbers in the illustration refer to the numbers in the table

	Fault codes	Description	Check	Location	Components	Adjustment	Calibration
1 Vehicle	Fault codes for all systems in the vehicle.						
2 System	Fault codes for one system.	Description of the system.					
3 Control unit	Fault codes for the control unit.	Description of the control unit.		Location diagram for the control unit.	Overview of the control unit and its circuits.		
4 Server	Fault codes for a server in the control unit.	Description of the server.	Troubleshooting the vehicle using tests linked to a control unit.			Adjustment of current control unit	Calibration of current control unit.
5 Component group	Fault codes for circuits in the component group.						
6 Circuit	Fault codes for the circuit.		Description of and troubleshooting a circuit. The circuit diagram is shown and signals can be read and activated	Location diagram for circuit components.	Description of circuit components.		

Fault codes

You can read and clear fault codes here. You can see which fault codes are registered. You can choose to view fault codes for the entire vehicle or for each control unit.

The exclamation mark indicates that there are fault codes. The exclamation mark is displayed all the way from the vehicle level down to the circuit where the fault is located.

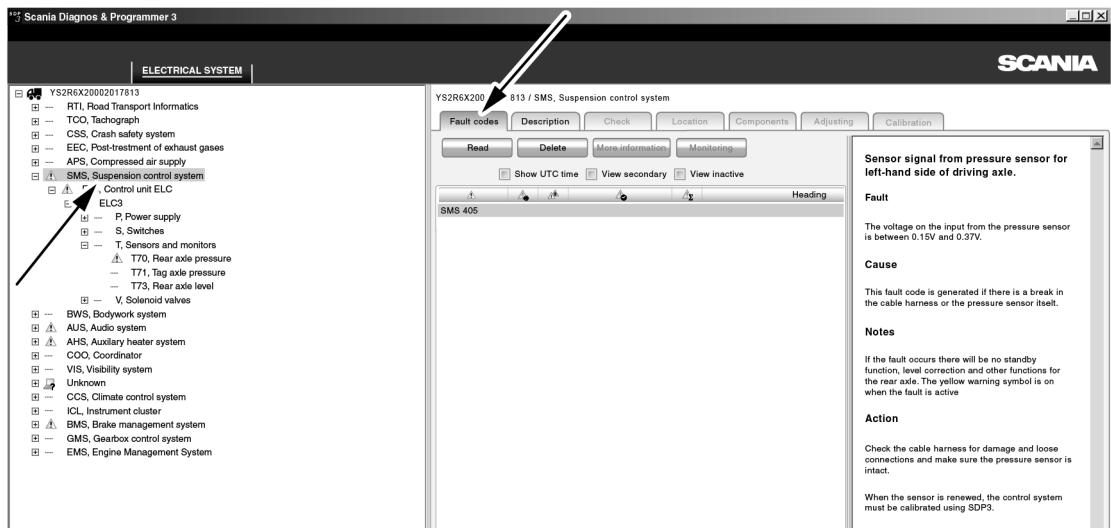

Fault codes. Fault code information for the vehicle is shown here.

The fault codes are divided into active and inactive ones. Active fault codes are fault codes which have been registered and where the fault persists. Inactive fault codes are fault codes which have been registered but where the fault has then disappeared.

The fault codes are also divided into primary and secondary fault codes. A primary fault code is an original fault code. A secondary fault code means a fault code which has been registered in a control unit because a primary fault code has occurred in another control unit.

Active and primary fault codes are always displayed, and you can then choose whether you also wish to view inactive and secondary fault codes.

The default setting for the fault code time stamp is local time. You can have the time shown in UTC time instead.

For certain industrial and marine engines, you can choose to display fault code area 2. All fault codes ever registered are then displayed. The fault codes in fault code area 2 cannot be deleted.

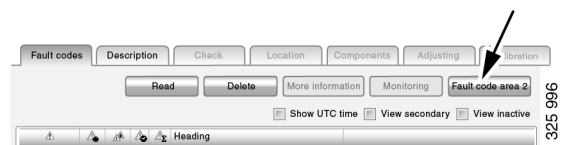

Background information

It is possible to read saved background information from the vehicle for some fault codes under the button More information. The information consists of some values which can be useful during troubleshooting.

It is important to remember that the values are not stored at exactly the same time as the fault code is generated. The control unit carries out several diagnostic tests before deciding to generate a fault code. The values are stored when a possible fault is detected whereas the actual fault code is generated later in many cases. Therefore it may appear as if the displayed values do not correspond with the time when the fault code was generated.

Fault code monitoring

Here you can obtain help to check that a fault really has been resolved after you have rectified it, i.e. that the fault code will not recur. Fault code monitoring is used for those fault codes where the fault does not become active immediately, but for which more complicated verification in the control unit is required before the fault code is set.

Here you can obtain a continuous read-out of the fault code status. This should be done when:

- it is necessary for certain conditions to be met in the vehicle so that the control unit can test and verify the fault code.
- the fault code is cycle filtered, which means that the control unit does not set an active fault code until it has tested it four times with a negative result.
- the fault code has a long validation period

When you have selected a fault code which is monitored, the button is active. You can then access and monitor that particular fault code.

If you have not selected a fault code, you can click on fault code monitoring and select from those fault codes which are monitored. This can be used when fault codes are deleted.

The conditions that apply to the way in which the control unit verifies the fault codes are described in the relevant fault code text.

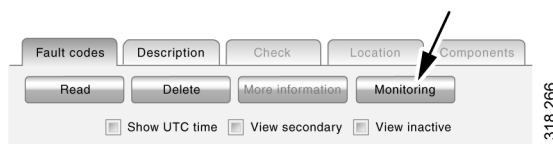

Description

A more detailed description is shown here based on where you are in the navigation tree.

There are descriptions for the System, Control unit and Server levels.

The screenshot shows the Scania Diagnos & Programmer 3 interface. The left pane displays a navigation tree under 'ELECTRICAL SYSTEM' with 'E 43, Control Unit EBS' selected. The main pane shows the description for 'Control unit EBS' with the following text:

EBS supplies compressed air to the wheel brakes electronically.

Unlike conventional pneumatic brake systems, EBS controls the braking process electronically on all axles. EBS is activated when the starter key is in the start position or the brake pedal is depressed without the starter key being activated – so-called wake-up mode.

The control unit has four driver stages (only two for the basic control unit) and these driver stages each send supply voltage to their control module. For 4x2 vehicles, two driver stages are active (front and rear).

The EBS system has self-learning parameters which the system calculates during operation to optimise braking capacity.

In cases when the electronics are out of order, the service brakes will work through the conventional pneumatic system (backup system).

The following text applies only to vehicles equipped with ESP:

The ESP function is available for the 4x2, 6x2 and 6x2/4 configurations.

The ESP function helps to stabilise the vehicle in hazardous driving situations, such as when there is risk of tipping over, and in case of over and understeering. This is done by monitoring the signals from the ESP sensors and wheel speed sensors so that the brakes can be applied individually on each wheel, either on the vehicle only or a tractor and trailer combination as necessary.

Scania part number (supplementary number)
1863281

Type:
BMS EBSS

VIN number:
Ys2R4X20002034123

Hardware number:
1756961

Software number:
1863282

Software version:
0001

Serial number:
MH1E9BD7QU

At the bottom of the interface, there are status indicators for pressure (9.3 bar) and voltage (23.5 V).

Description. The various vehicle electronic control systems with control units and servers are described here.

Check

A circuit diagram for the circuit marked in the navigation tree is shown here. You can read signals from the control unit and activate different functions and components in order to check whether the circuit is working as expected. Descriptions can be found in the same window.

If you place the mouse pointer on a cable harness in the circuit diagram, the cable

marking is displayed.

If you place the mouse pointer on a connection pin, the terminal part number, relevant crimping tool, dismantling tool and cable marking are displayed.

You can change the size of the circuit diagram with the + and – keys.

The screenshot shows the Scania Diagnos & Programmer 3 interface. The main window is titled "V82, Control module, front" and contains a table of sensor data, a circuit diagram, and a detailed information panel for selected components.

Driver stage, front contro...	0.0	12.0	0.0 bar
Pressure, wheel 1	0.0	12.0	0.0 bar
Pressure, wheel 2	0.0	12.0	0.0 bar
Wear sensor, power supp...	0.0	5.0	0.0 V
Wear sensor, signal volta...	0.0	6.0	0.0 V
Wear sensor, power supp...	0.0	6.0	0.0 V
Wear sensor, signal volta...	0.0	5.0	0.0 V
Speed, wheel 1	0	km/h	
Speed, wheel 2	0	km/h	
Start speed, wheel 1	3	km/h	

The detailed information panel for the selected component (B-15) shows:

- Connection point:** B-15
- Part No.:** 1443343
- Crimping tool:** 99491:B
- Dismantling tool:** 588192/99596
- Cable marking:** BM56.OG-1

The circuit diagram shows connections between components E43, C101, and V82. The detailed information panel also includes descriptive text for various sensors and their functions, such as "Wear sensor, power supply, wheel 1" and "Speed, wheel 1".

Check. The vehicle circuits can be checked here.

Right-clicking on a component in the circuit diagram takes you directly to a user function in the user function view.

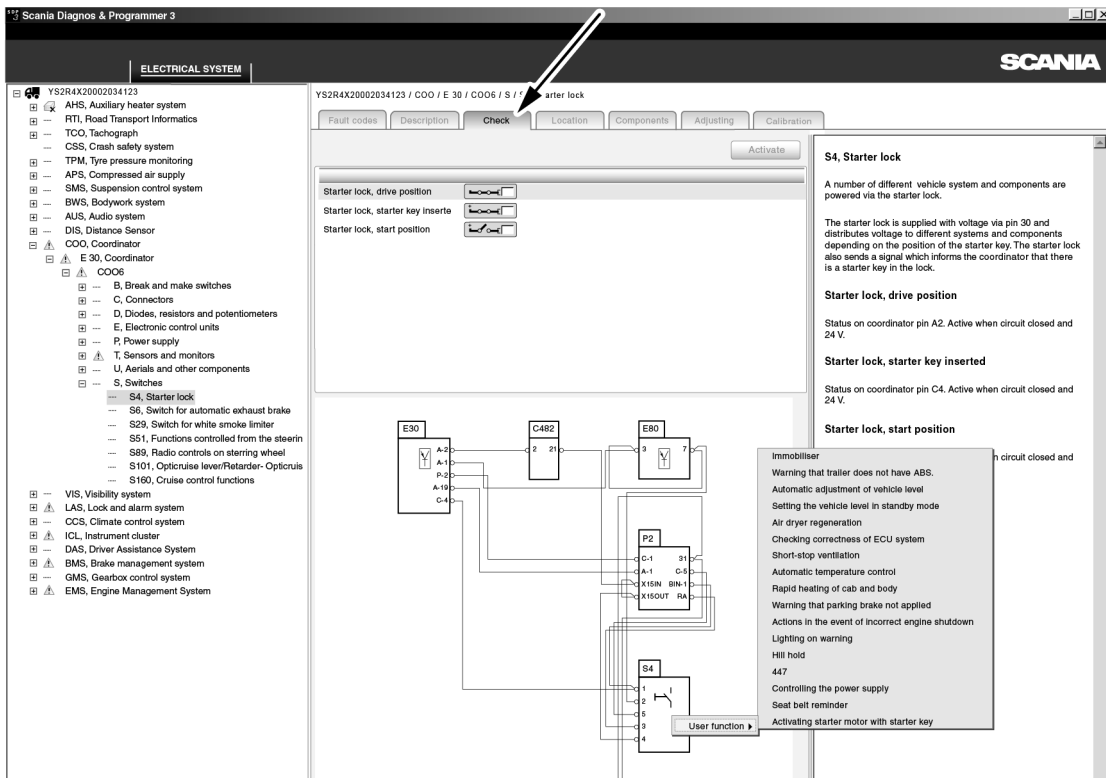

Navigation from circuit to user function.

If you click on the symbol to the right of the read value, the value is presented in a diagram.

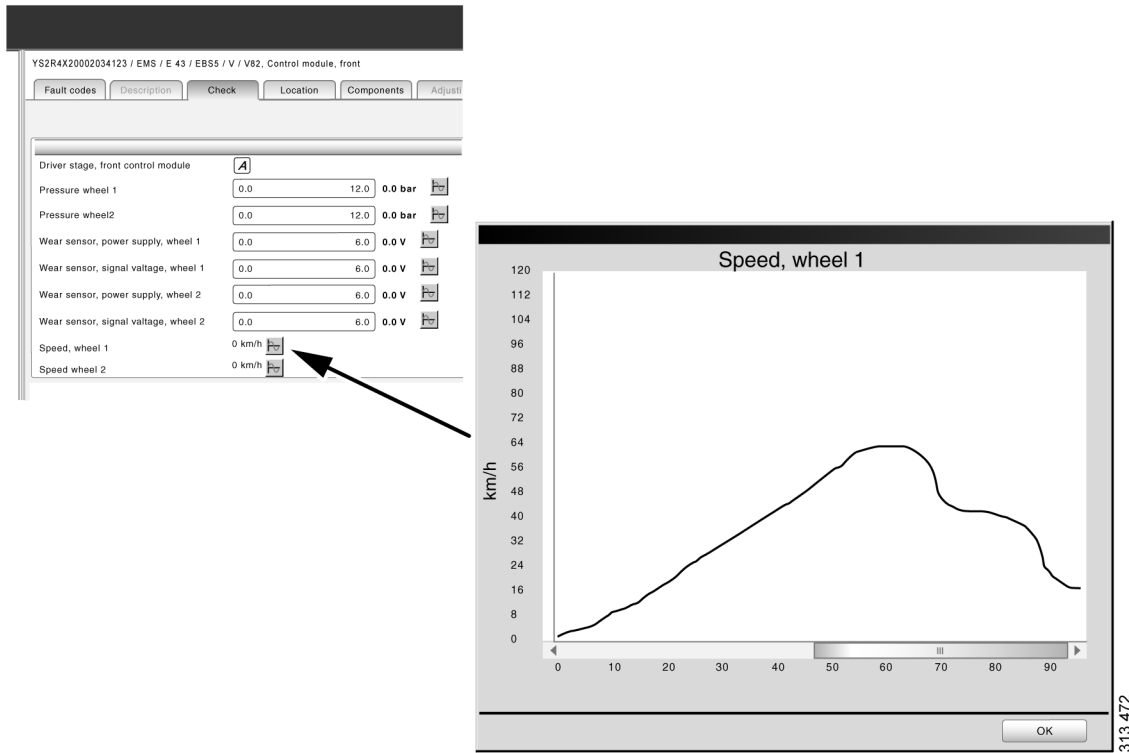

The diagram is displayed in real time. Example with wheel speed: The curve is recorded as the speed increases/decreases.

From the server level in the navigation tree, you can carry out a number of checks linked to each server.

Check. A number of checks can also be carried out at the server level. In most cases, the result of the check can be saved and stored in the "Reports" directory created when SDP3 was installed.

Activation

When you start up the activation window (1), SDP3 takes control over the inputs and outputs of the control units concerned.

You choose what to activate by entering a value or a status (2). When you press the button (3), the value is sent to the control unit. The current status is displayed to the right of the button.

The activation button works differently depending on what is required during the particular activation being carried out. The following options are available:

- Activation takes place when you press the button and to stop activation you have to press the button again.

Some activations have a time limit which means that the activation ceases automatically after a certain time. Then the button is also reset.

- Spring-loaded button: you have to hold down the button during activation.

When activation ceases, the value is reset to its original level.

It is only when you exit and close the activation window that the control unit goes back to checking the components concerned.

As a safety feature, activation can always be interrupted by pressing the space bar.

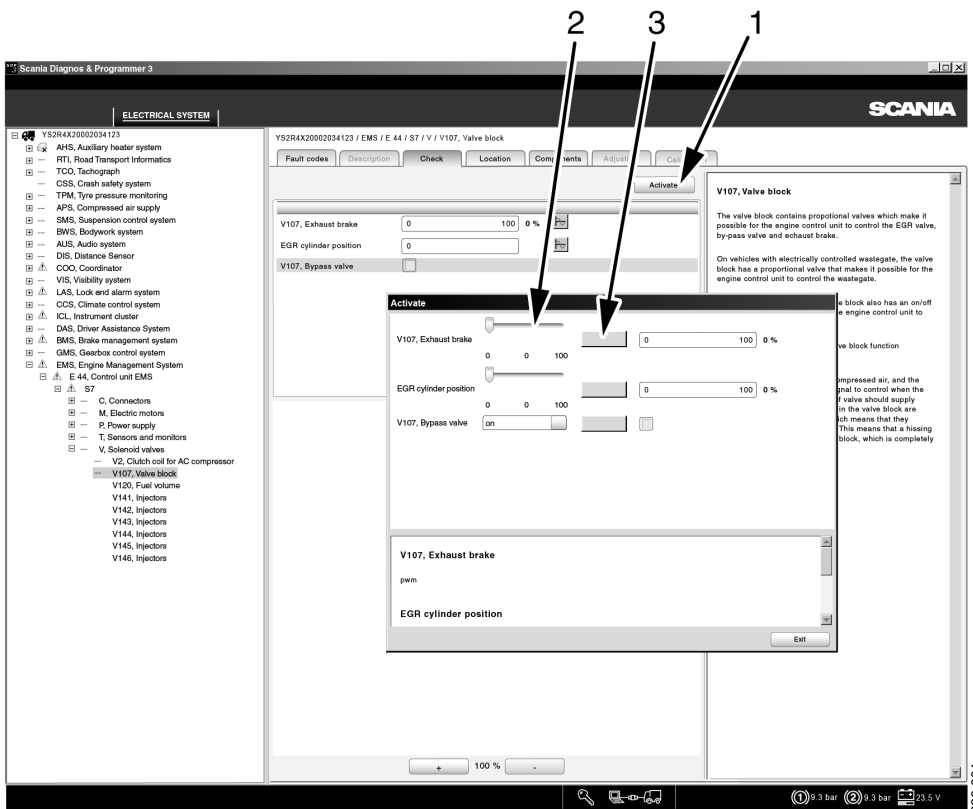

Here it is possible to check the vehicle components by activating them using SDP3.

Location

Diagrams are displayed here, which indicate where on the vehicle a particular electric component is located.

If there are several location diagrams for the components in the circuit, use the arrows below the diagram to move between the diagrams.

If you double-click on a diagram, a new window opens to display the diagram. This enables you to have the diagram open while working with other activities in SDP3. The same applies to other diagrams in the program.

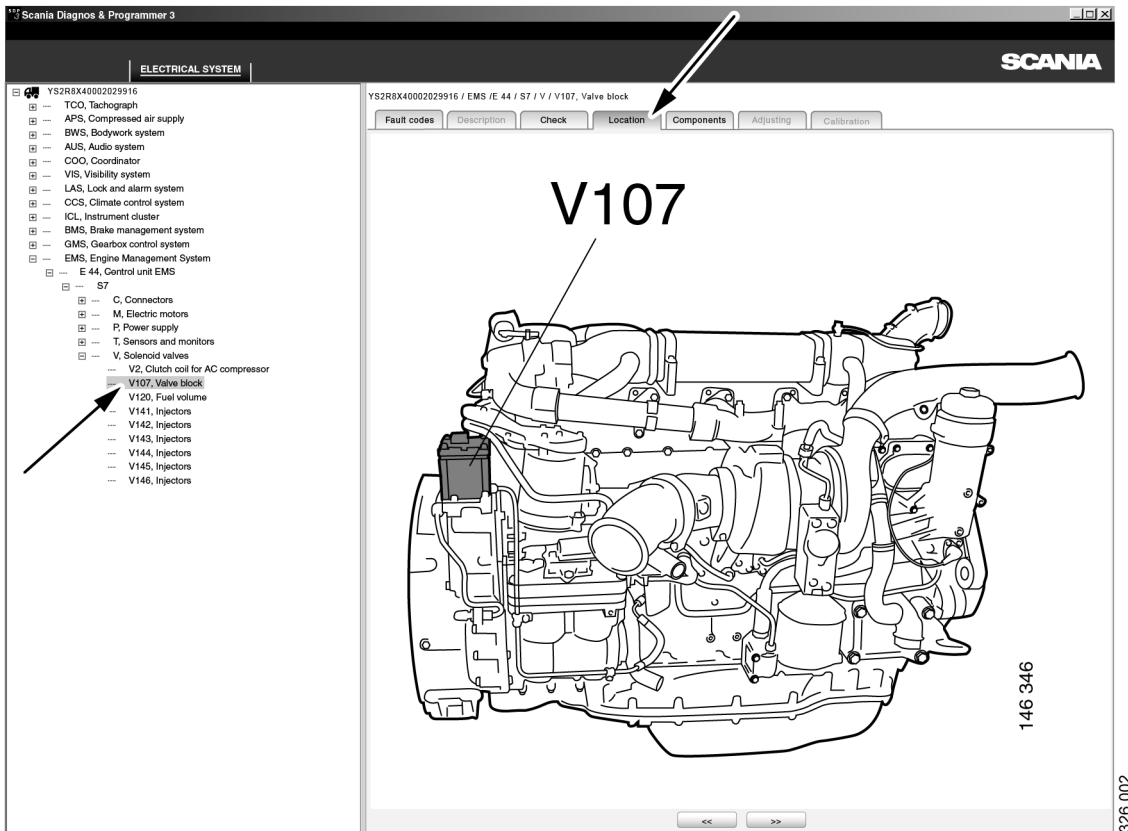

Location. Location diagrams for the components in the circuit are displayed here.

Components

Here you find a more detailed description of the components which are included in a circuit. Select between relevant components in the list above the diagrams.

Where there are several component diagrams, use the arrow keys below the diagram to move between the diagrams.

The screenshot shows the Scania Diagnos & Programmer 3 software interface. The main window is titled "ELECTRICAL SYSTEM" and displays a list of components on the left. The selected component is "V107, Valve block". The central area shows a 3D model of the valve block and a schematic diagram below it. The right-hand panel provides a detailed description of the component and a table of connection numbers and uses.

V107, Valve block

Valve block which contains two proportional valves and an on/off valve. The proportional valves have a resistance of approximately 30 Ω and 127Ω.

Connections number	Use
1	EGR valve, voltage supply
2	Exhaust brake, earthing
3	
4	Bypass valve for EGR cooler, voltage supply
5	Bypass valve for EGR cooler, earthing
6	
7	Exhaust brake, voltage supply
8	EGR valve, earthing

- Resistance 20-30 ohms
- Inductance 152-550 mH
- PWM frequency 100 HZ

Components. Descriptions for the components in the circuit are displayed here.

The connection of controllable components to the control unit is displayed in the navigation tree at system level. Place the mouse pointer on a cable harness to get information about which checks can be carried out on the circuit under the tab *Check*.

If you press the right mouse button, the text box disappears but the highlighting remains so that you can see the connection.

Place the mouse pointer on a component and press the right mouse button to navigate directly to the particular user function, circuit check or to information about the component. This function works for most components.

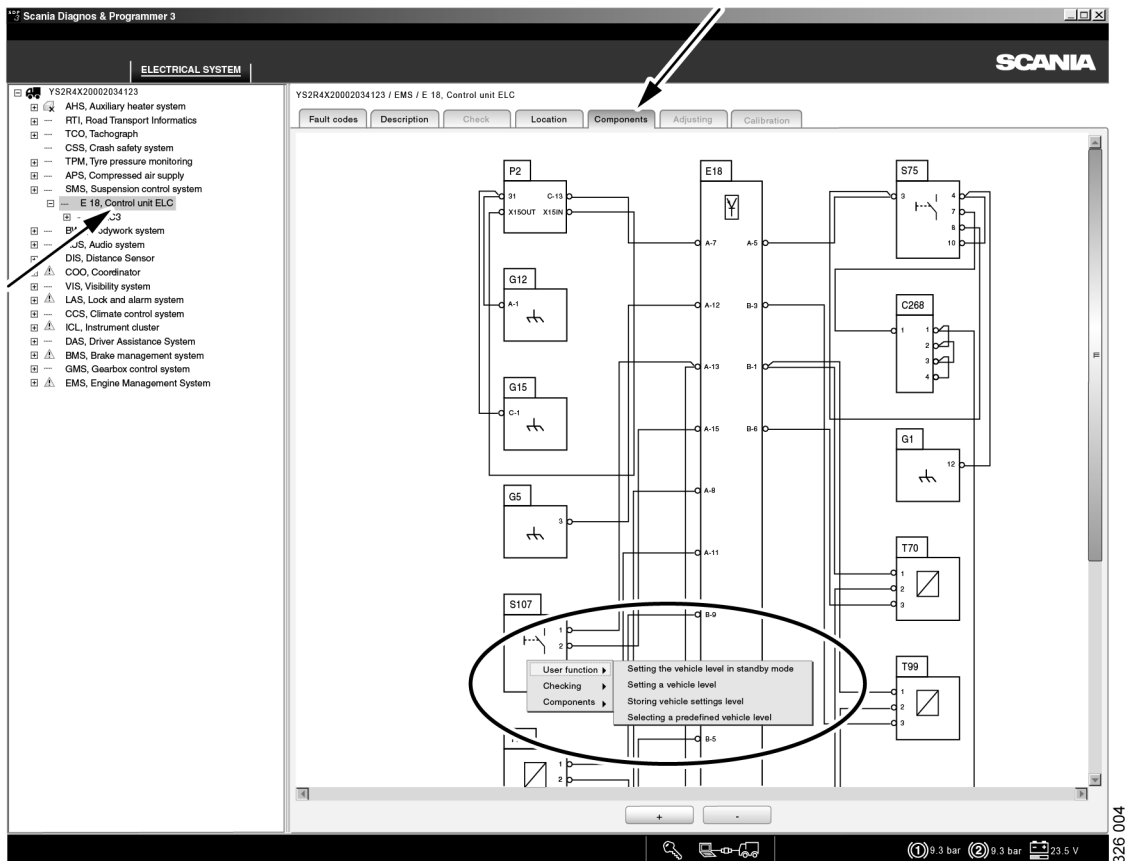

Adjustment

Under Adjustment, you can view the customer parameters which can be changed and their current values.

The information is retrieved from the control unit and displays the stored value.

During adjustment **it is possible** to save the settings made so that they can be reused when renewing a spare part.

You should have checked the vehicle and rectified any fault codes before carrying out an adjustment.

- 1 To carry out an adjustment, press the Change button.

- 2 Select a new value.

If a value is changed, a red dot is displayed on the status field for the customer parameter.

The star displays the value that was set at the factory.

- 3 Then press Execute.

When you carry out the adjustment, the changed customer parameters will be marked with a green tick if the adjustment was successful.

If the adjustment failed, the red dot will remain for the changed customer parameters.

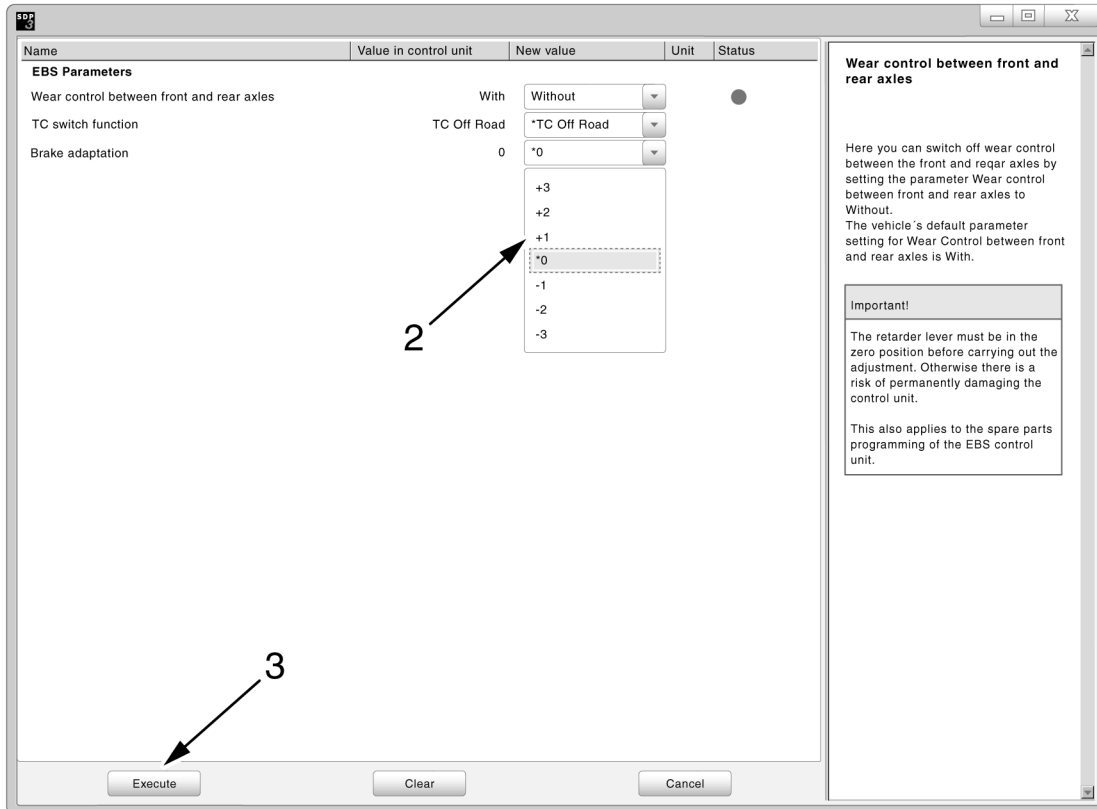
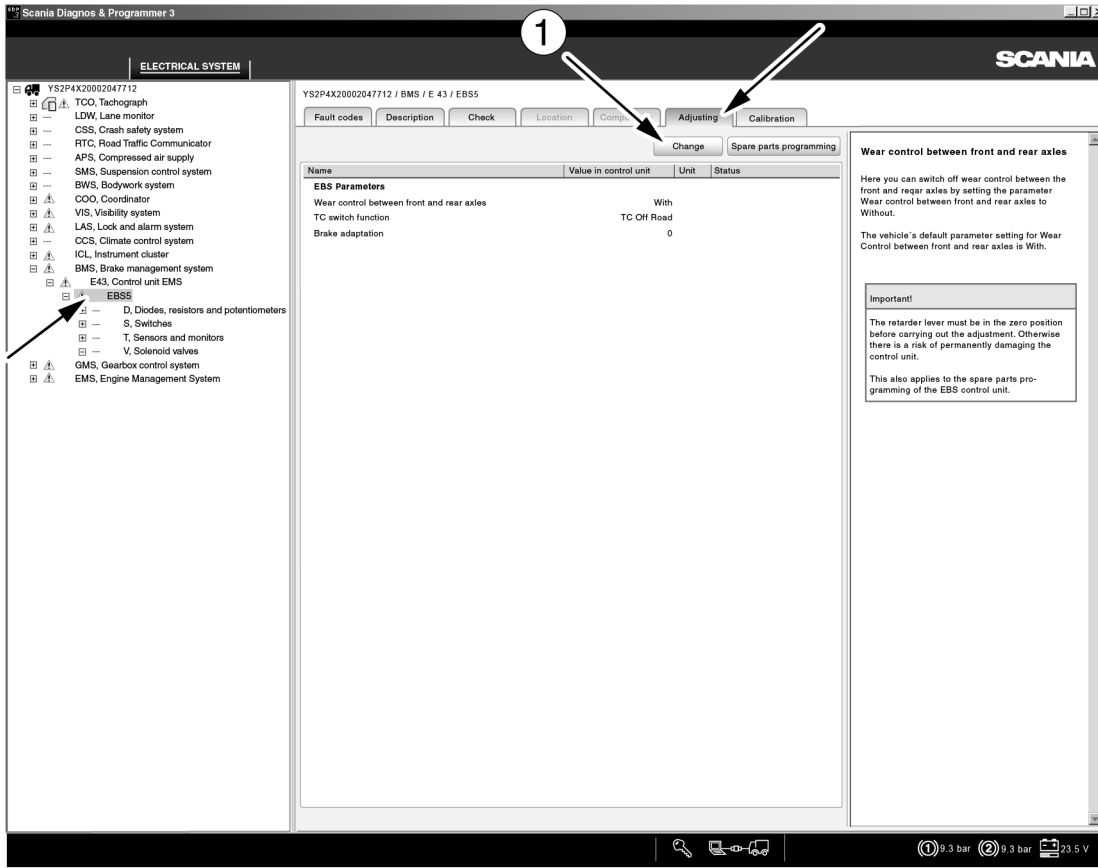

Procedure when adjusting customer parameters on the vehicle.

Calibration

There is also an option to calibrate and reset the values in the vehicle control unit.

During calibration **it is possible** to save the settings made so that they can be reused when renewing a spare part.

- 1 Highlight what you wish to calibrate and proceed by pressing the arrows.
- 2 A wizard will now appear which will help you to carry out the calibration.

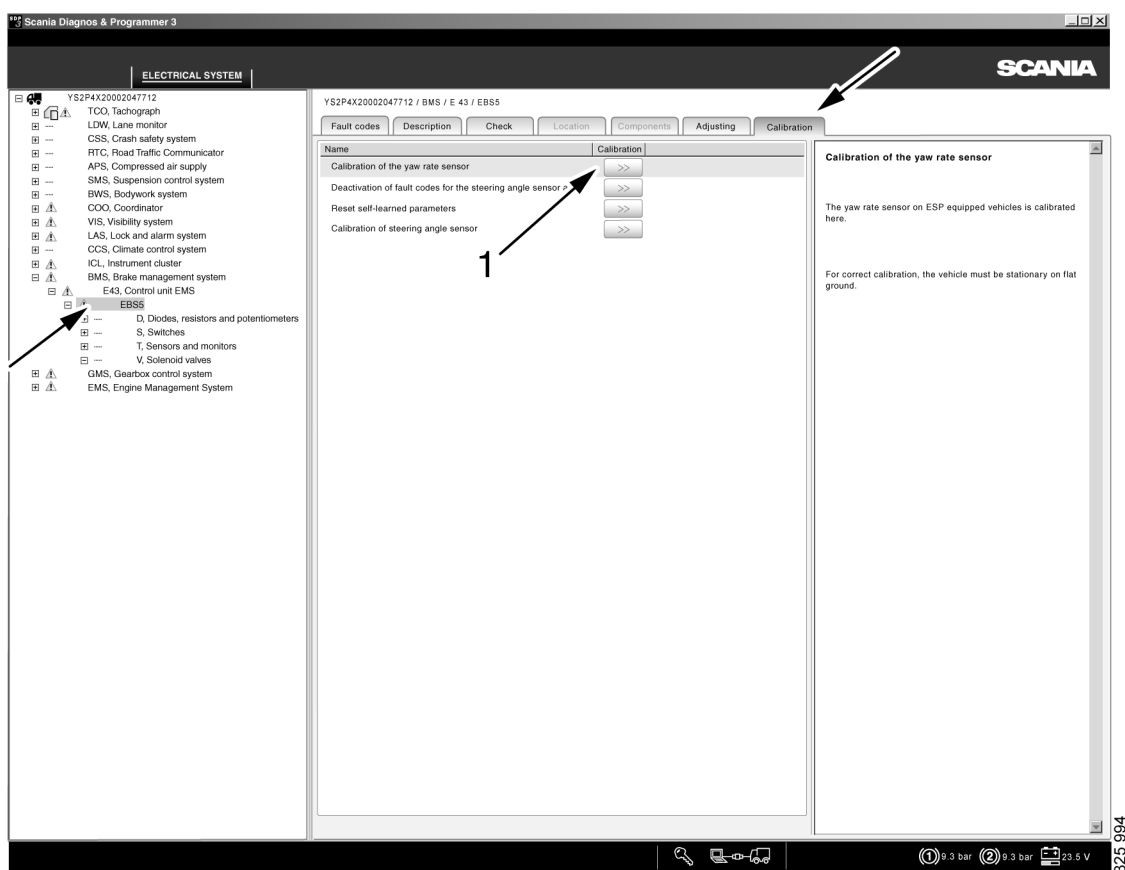

Calibration and resetting is carried out under Calibration.

Troubleshooting via User functions

Here you can troubleshoot by starting from the vehicle's user functions.

Navigation under User functions is divided up as follows:

1 Vehicle

2 Group of user functions

The user functions are grouped into categories. Gearbox control is one example of a category.

3 User function

One user function in the Gearbox control category is the Opticruise system.

4 Use case

Examples of an Opticruise system use case:

- Activation of automatic gear changing
- Selecting gear manually
- Setting the starting gear

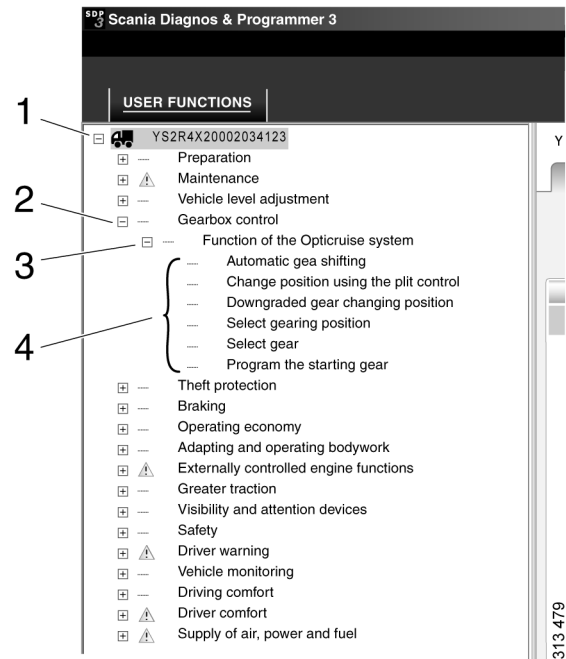

Levels when navigating under User functions.

The content under the different tabs varies, depending on where you are in the navigation tree.

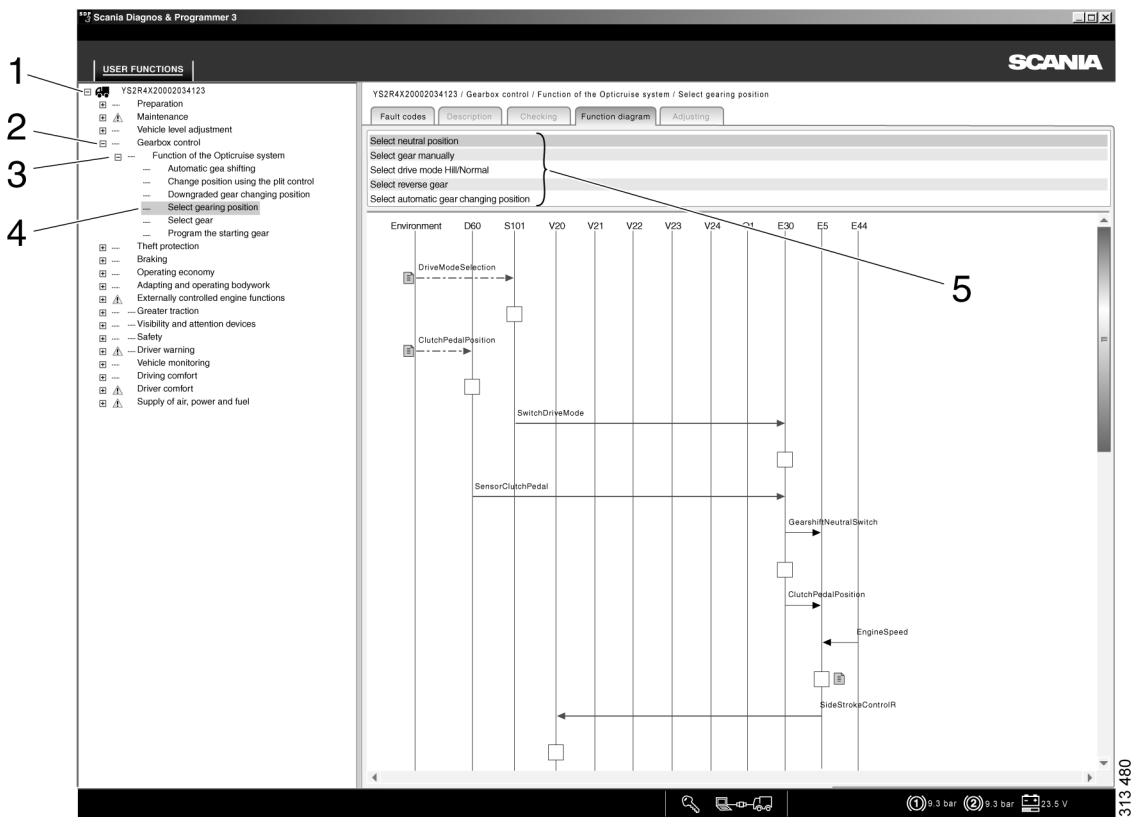

The table below gives an indication of what sort of information the tabs contain on the different levels.

	Fault codes	Description	Check	Function diagram	Adjustment
1 Vehicle	X				
2 Group of user functions	X	X			
3 User function	X	X	X		X
4 Use case	X			X	
5 Scenario (different ways in which the use case can be carried out)	X			X	

Fault codes

Here you can see which fault codes are registered for a user function.

Other information relating to fault codes is the same as for fault codes under electrical system.

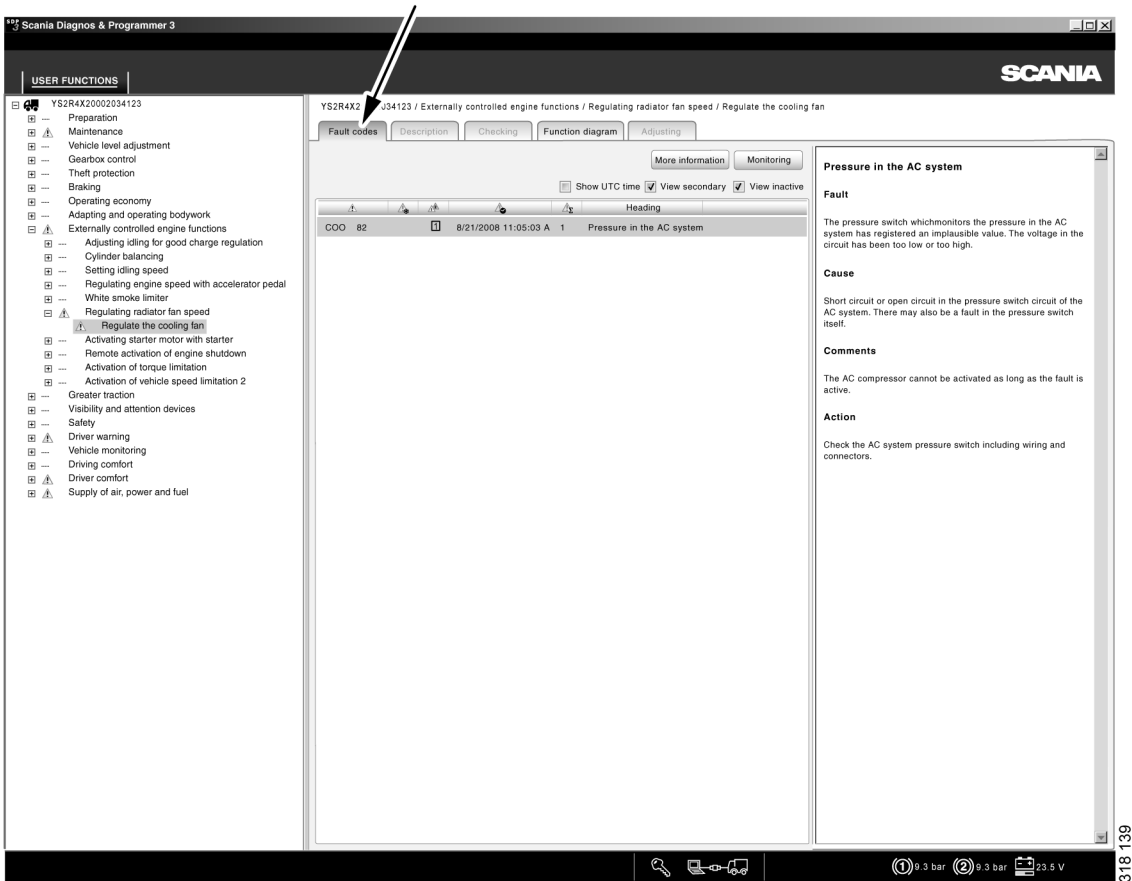

Fault codes. Fault code information for the vehicle is shown here.

Description

Here you can obtain a brief description of the vehicle's user functions.

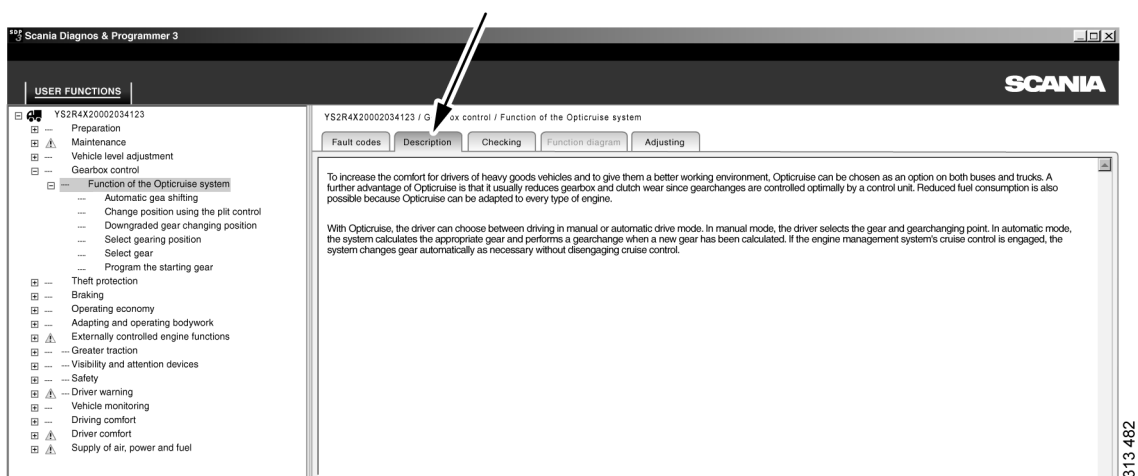

Description. Descriptions of the vehicle's user functions are displayed here.

Check

You can carry out checks on some of the vehicle's user functions here. Unlike checks under the Electrical system, these checks may work on several interrelated control units.

Function diagram

The function diagrams which are available for a user function are displayed here. The function diagrams provide a visual representation of the function. They provide an overview of the control units and other components which are involved in a user function in the specific vehicle. They also show the order in which signals travel between the components concerned.

A blue broken arrow (1) shows the influence from the circumstances, e.g. the driver turns the key.

A blue continuous arrow (2) shows conventional electrics. There must be circuits in the electrical system view to obtain these arrows, e.g. S4 closes + 24 V to E30.

A black arrow (3) displays CAN messages between different control units.

By right-clicking on a component (4), you can

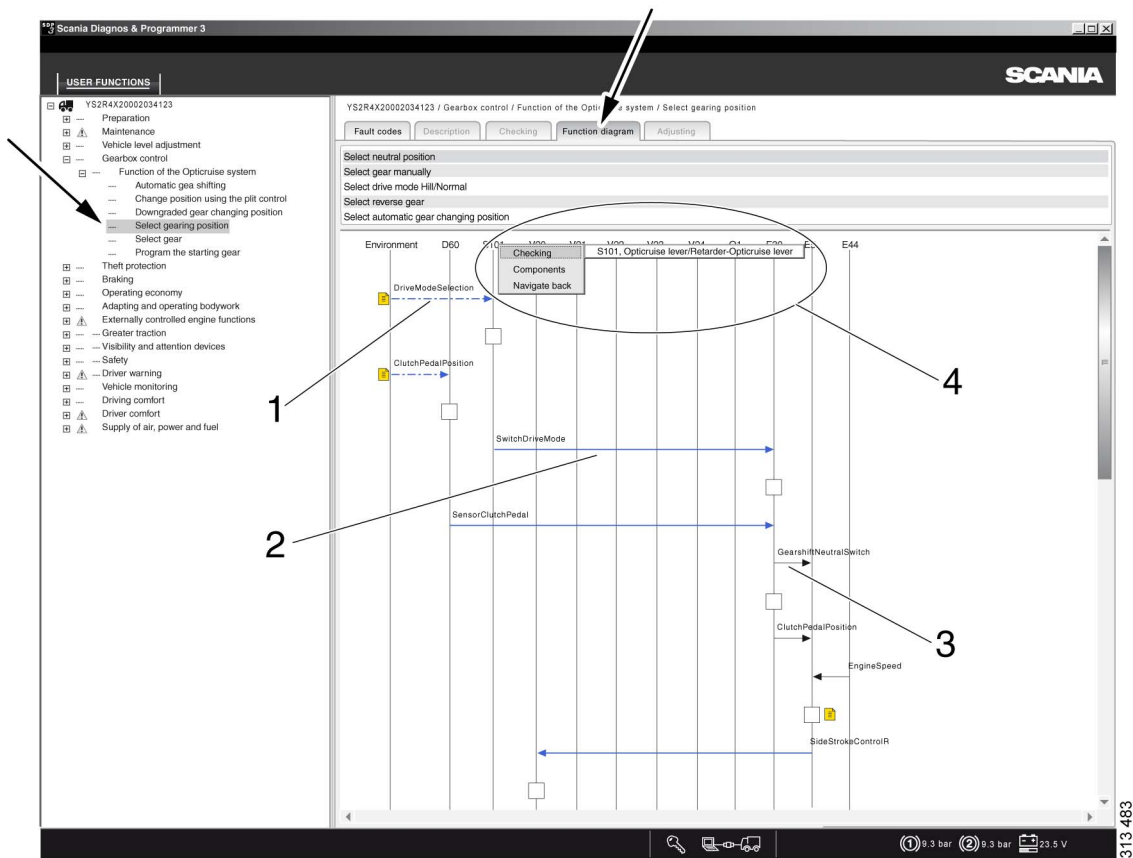

Function diagrams. A function diagram for the vehicle's user functions is displayed here.

Adjustment

Here you can calibrate a user function that extends over several control units.

Product information

Information on how the vehicle is equipped is found here, including the user functions which are available on the vehicle and electrical information from the chassis specification.

Information about the settings of the different control unit parameters is also available here. You can view when and which USB key was connected when the parameters were last changed.

You can also see any local conversions carried out on the vehicle.

PRODUCT INFORMATION		SCANIA
Product information / ECU system / COO7	ECU	COO7
	ECU family	COO
	Assembly part number	1914377
	Warnings	
	Lighting on indicator	With
	Warning that parking brake is not applied	Extended
	Indication of raised tag axle on trailer	Without
	Speed parameters	
	With or without ECO cruise	CC
	Adjustment	
	Adjusted charging voltage	With
	Adapted idling for battery charging	With
	With or without retarder lever	Without
	Setting the K factor	9765
	Next service	
	Reminder about next inspection	5000
	Next inspection	20000
	Limited hand throttle (mode 1) and predefined (locked) engine speed (mode 3)	Switch
	Selection of signal input for limited hand throttle (mode 1) and for predefined (locked) engine speed (mode 3)	Switch

Specification information for the vehicle.

Conversion

Here you can set the correct parameters in the vehicle control units after a conversion.

General

In the Conversion work option, you can carry out "major adjustments" of the vehicle, i.e. conversions. You should have checked the vehicle and rectified any fault codes before selecting this work option.

The control units affected by a conversion can reset certain control unit settings and calibrations. Make sure that the control units concerned have the correct parameters set and also make sure that after a conversion you calibrate the control units which may have been affected.

Note: Scania cannot accept responsibility for conversions carried out on a vehicle which contravene the national regulations in a specific country.

Local conversion

You can obtain information about any local conversions here. You can carry these out yourself by setting the parameters covered by the conversion. When you choose to carry out the conversion, the affected control units are reprogrammed.

After conversion, you must report the changes to Scania by sending in the changed SOPS file. The report is a prerequisite for being able to show correct vehicle information in Scania Multi.

Procedure

- 1 Start SDP3 and select the Conversion work option.
- 2 Read and rectify any fault codes registered in the vehicle.
- 3 Highlight the vehicle level in the navigation field and select Local conversion (1).
- 4 Highlight the conversion you wish to carry out and proceed (2).
- 5 Set the new values for the parameters concerned (3).
- 6 Select OK (4).
- 7 Save the SOPS file by selecting Save SOPS (5).
- 8 Calibrate and reset any control units which may have been affected. Adjustment can be carried out from the same view in the program.
- 9 Report by sending in the changed SOPS file to Scania.

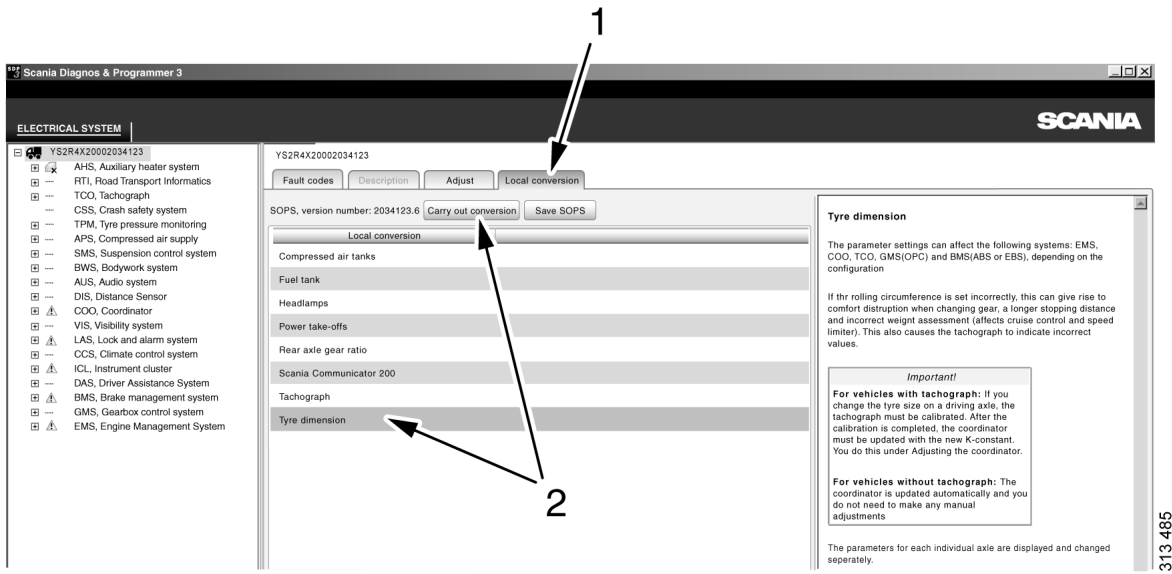

313 485

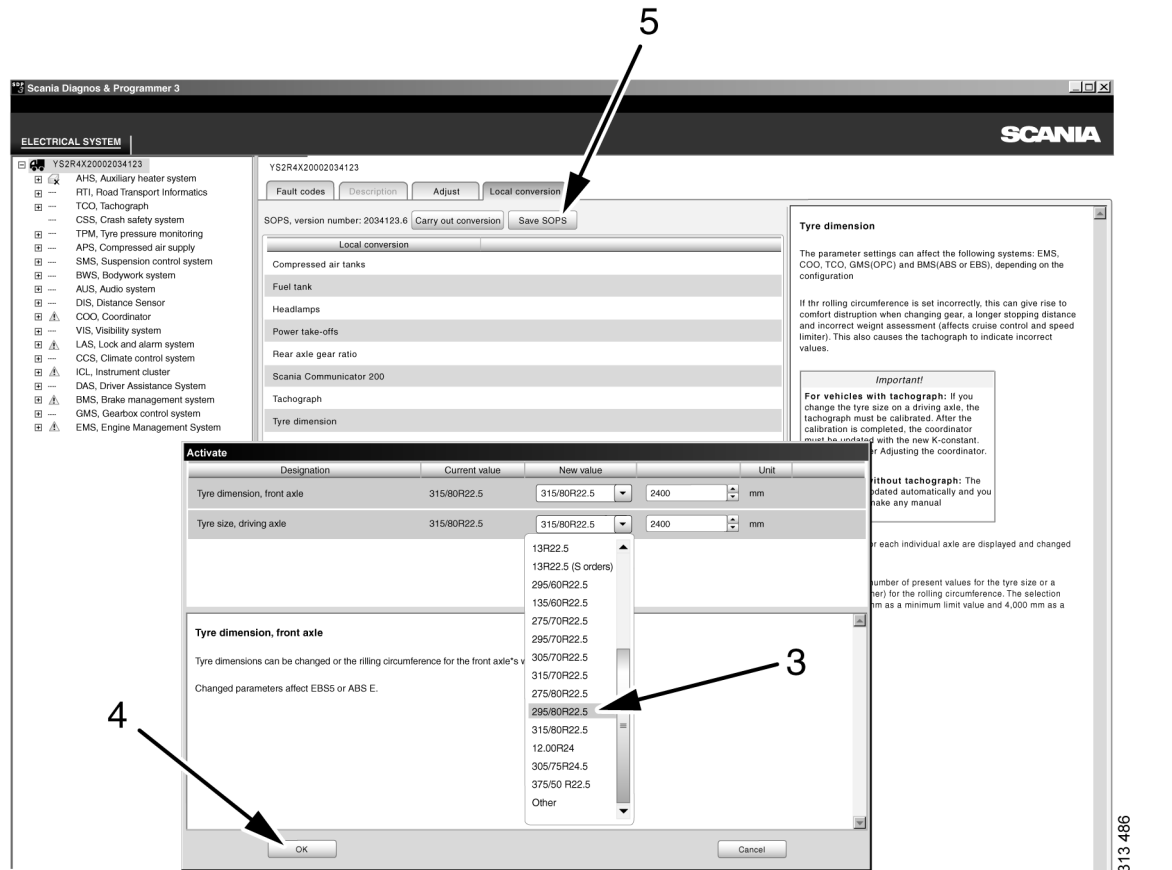

313 486

Procedure during local conversion. The text on the previous page refers to the numbers in the illustration.

Factory supported conversion

Information is provided here about how to carry out conversions which require you to contact Scania.

Factory supported conversion means briefly that you exchange the vehicle's existing SOPS file for an updated one which is either sent from your local Scania distributor or which you download via the SAIL web portal.

Always start by saving the vehicle's existing SOPS file, basing the update on it. When the file has been saved, no other conversions must be carried out on the vehicle. If a change is made, the contents of the new SOPS file will not correspond to the conditions applicable when the old file was used. It will not then be possible to use the updated SOPS file.

A completed factory-supported conversion must always be reported to Scania.

So there are two ways to update the vehicle's SOPS file:

- Upload the existing SOPS file via the SAIL web portal, order an update and then download the updated file from the same website.
- Send the existing SOPS file, including a description of the proposed conversion, to Scania. Scania will then send back an updated file once it has been approved.

Procedure

Start the conversion and save the SOPS file.

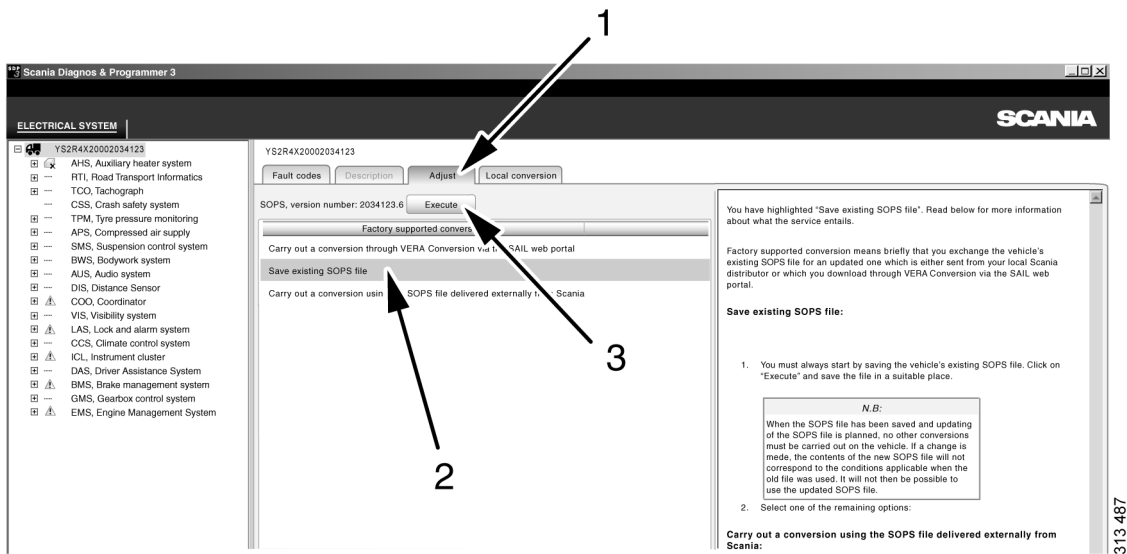

- 1 Start SDP3 and select the Conversion work option.
- 2 Read and rectify any fault codes registered in the vehicle.
- 3 Highlight the vehicle level in the navigation field and select Adjust (1).
- 4 Highlight Save existing SOPS file (2) and Execute (3).
- 5 Select a suitable location to save the file.
- 6 Decide whether to use VERA Conversion via the SAIL web portal to update the file or whether to send it to Scania together with an order. The options are described on the following pages.

Carry out a conversion using VERA Conversion via the SAIL web portal.

Use this option if you choose to use the SAIL web portal to update the SOPS file. This option is always preferable provided that the proposed conversion is frequent and available.

- 1 Log on to the web portal with your SAIL access.
- 2 Upload your saved SOPS file as described in the instructions on the portal.
- 3 Enter your proposed changes as described in the instructions on the portal. Agree to order an updated SOPS file.
- 4 Make sure that the components required for the conversion have been added to the vehicle.
- 5 When the updated file is ready to be loaded into the vehicle: Return to SDP3, select "Carry out a conversion through VERA Conversion via the SAIL web portal" and press Execute.

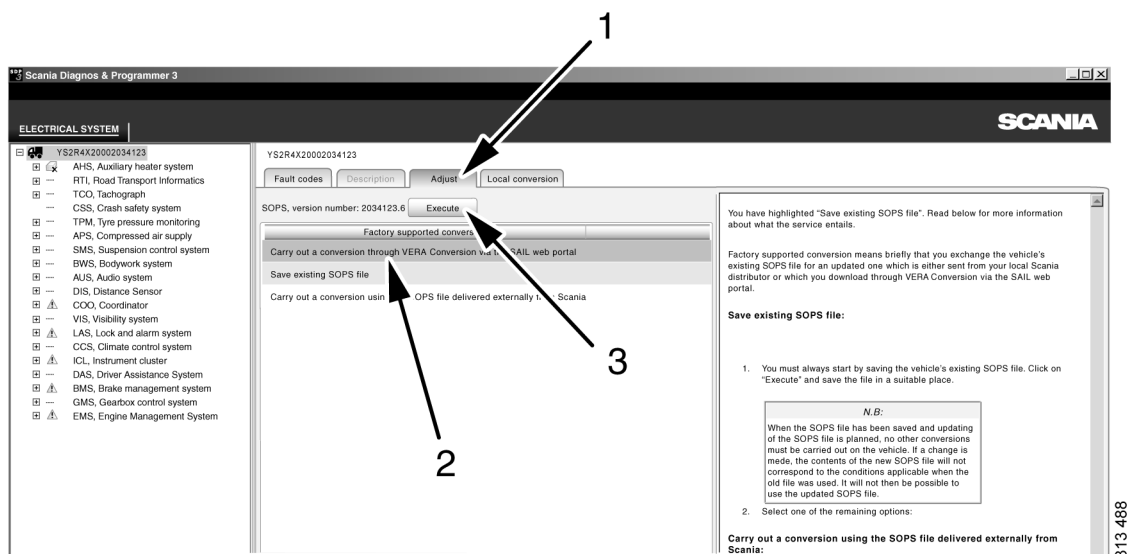

When the updated file is ready to be loaded into the vehicle: 1) Adjust, 2) Carry out a conversion through VERA Conversion via the SAIL web portal, 3) Execute.

- 6 SDP3 will ask you to log on to the SAIL web portal again. Enter your user name and password.
- 7 A work list is downloaded. The procedure for the various steps in the list is shown step by step on the screen.
- 8 When the conversion is complete, a confirmation is sent to Scania. Rectify any fault codes generated during conversion.
- 9 Certain customer settings for function parameters may have reverted to their default values during loading. Calibrate and reset any control units which may have been affected. Adjustment can be carried out from the same view in the program.

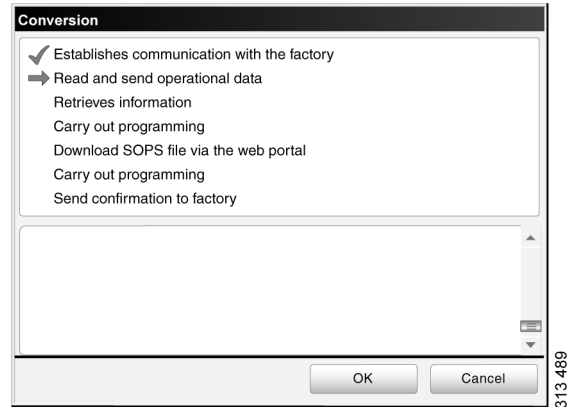

A conversion procedure is displayed step by step on the screen.

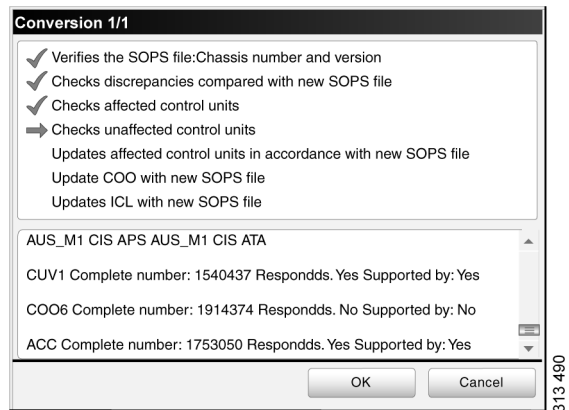

A separate procedure is displayed when the SOPS file is loaded. Information is also provided about the results of each stage of the procedure.

Carry out a conversion using SOPS file delivered externally from Scania.

This option applies if you choose to send the SOPS file to Scania and let Scania send back an update.

- 1 Describe your proposed conversion in detail and enclose the description with the SOPS file when you send it to your distributor. You can use e-mail or a CD.
- 2 Make sure that the components required for the conversion have been added to the vehicle.
- 3 When you have received the updated file: Return to SDP3, select "Carry out a conversion using the SOPS file delivered externally from Scania" and press Execute.

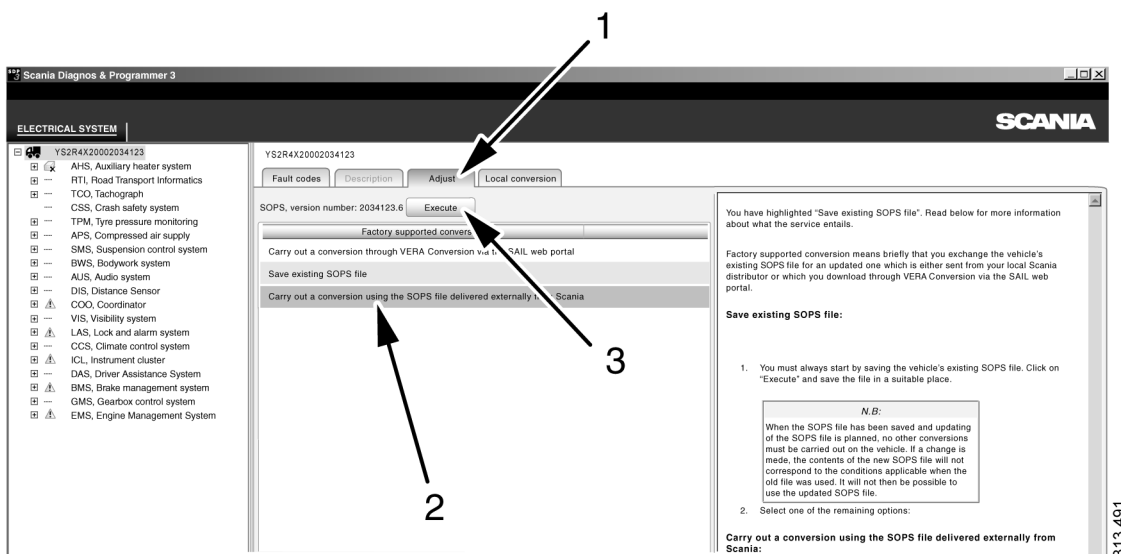

When the updated file has been sent back and is ready to be loaded into the vehicle: 1) Adjust, 2) Carry out a conversion using SOPS file delivered externally from Scania, 3) Execute.

- 4 Open the SOPS file. The file will then start loading. The procedure is shown step by step on the screen. The SOPS file is verified and the control units concerned are updated. Follow the procedure on the screen.
- 5 Notify Scania when the conversion is complete and the SOPS file is loaded.
- 6 Rectify any fault codes generated during conversion.
- 7 Certain customer settings for function parameters may have reverted to their default values during loading. Calibrate and reset any control units which may have been affected. Adjustment can be carried out from the same view in the program.

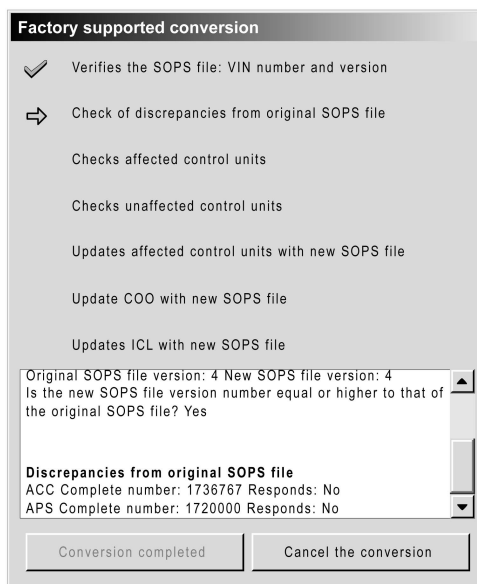

When loading the SOPS file the procedure is shown step by step on the screen. Information is provided about the results of each stage of the procedure.

Inspection

In the Inspection work option you can access limited parts of the program which are required during an inspection.

The parts which are currently accessible are connecting, checking the control unit parameters and support for reading fault codes.

You can also save and analyse the vehicle's stored operational data via the menu option View stored operational data. You can also read more about how this works in the section later on that describes View stored operational data.

ECU update

Support is provided here to update the software of control units using SDP3. Software updates must only be carried out when prompted by Scania via information sent out by Scania.

In order to carry out the update you need the ECU update number. This can be found in the information about the software update sent out by Scania. In addition, the computer must have a network connection to Scania and you must have SAIL access. You also need to have a certificate for your computer and belong to the VERA_user group. You can find out how to

obtain a certificate and how it operates from the Service Development website under Workshop Tools & Equipment. You can access the website via SAIL.

When you enter the work option ECU update, you can access the electrical system view where you can check and clear fault codes before starting the software update.

When you start the ECU update, instructions are given in the program.

Scope

The work comprises

- preparations
- connecting to Scania and downloading new software which is temporarily stored on your local computer
- updating the control unit
- finishing work checking any fault codes in SDP3.

Preparations

- 1 Check that you have a valid SAIL account.
- 2 Check that your access includes the group VERA_user.
- 3 Check that a valid Scania certificate is installed on the computer.

Note: If the computer does not have a valid Scania certificate software updates cannot be performed.

- 4 Check that there is power supply to the computer and that the vehicle batteries are charged or that there is power supply to the vehicle.
- 5 Check that the computer is connected to the vehicle and connected to the Internet via a telephone modem or broadband connection.
- 6 Check that the SDP3 version installed on the computer is the latest version. The latest version can be downloaded from TIL.
- 7 Check that the vehicle is stationary and that the engine is switched off and that the starter key is in the drive position.
- 8 Check that the vehicle is fully functioning without fault codes and with spare parts programmed control units.

- 9 Check that the computer is not set to shut down or to enter standby mode. Change the setting via *Start > Settings > Control panel*, see figure 2 and 3.
- 10 Check that the VCI is connected correctly to the vehicle.

Note: Disconnect large current consumers such as trailers, auxiliary lamps or similar, in order to avoid that the batteries are discharged.

Figure 2



300 086

Figure 3

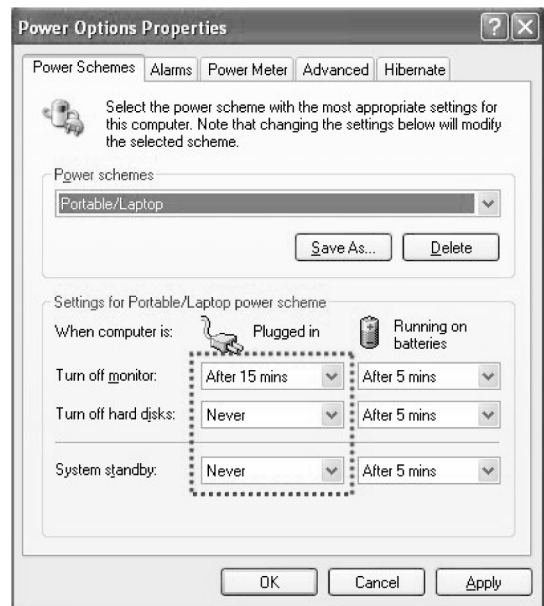

300 087

Work description

Connection to vehicle

- 1 Connect the computer to the vehicle via the VCI connection.
- 2 Start SDP3.

Downloading new software

- 1 Click on the *ECU update* button, see figure 4.
- 2 A new window opens. Click on the *Start* button. A new window opens which displays that SDP3 is connected to the vehicle, see figure 5. A new window also opens for logging on to Scania.
- 3 Enter your user name and password for SAIL.

IMPORTANT!

If the user name or the password is entered incorrectly 3 times the user is blocked from SAIL. The user is blocked without any prior warning.

Figure 4

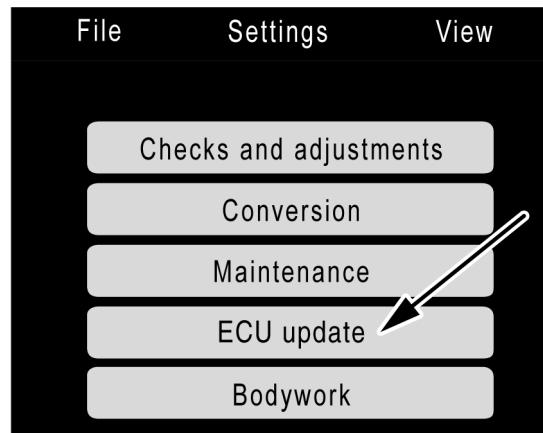
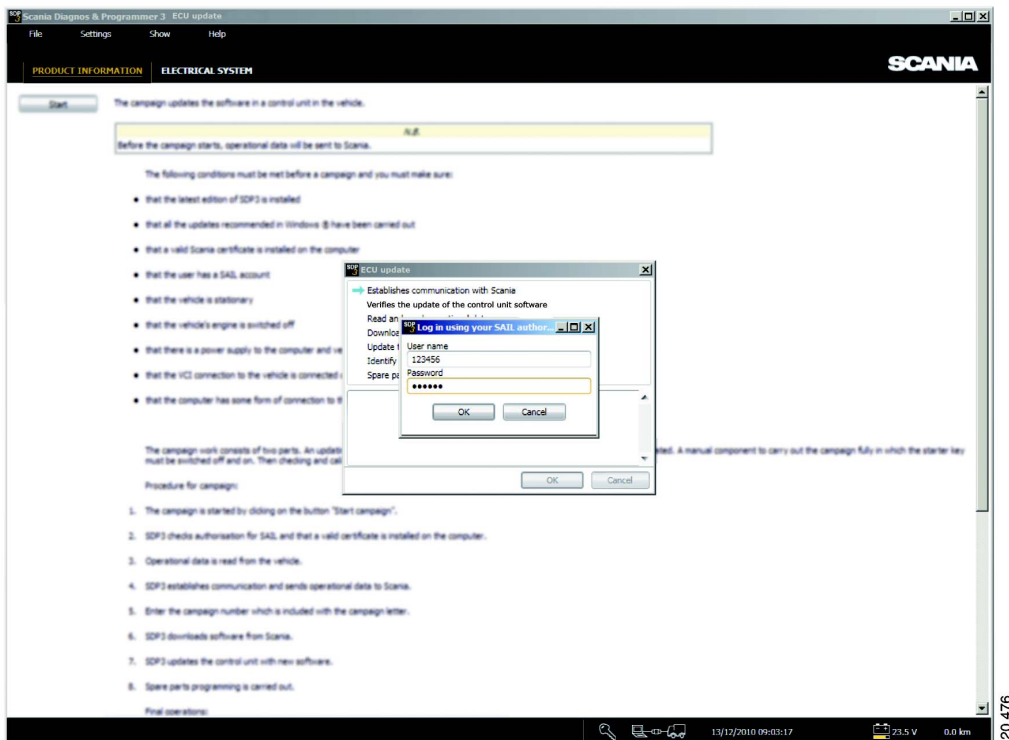
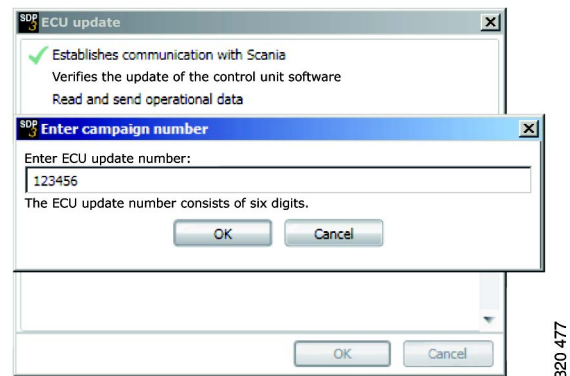

Figure 5



- 4 When you have logged on successfully a new window opens. Enter the 6-digit number for the ECU update (can be found in the page header), see figure 6. Then click *OK*.

Figure 6



- 5 The previous window closes and SDP3 downloads operational data from the vehicle, see figure 7.

The data is downloaded from Scania and stored temporarily on the computer hard drive.

Note: Downloading can take a few minutes.

Note: If downloading operational data from the vehicle or uploading operational data to Scania fails, the software update can still be completed.

Figure 7

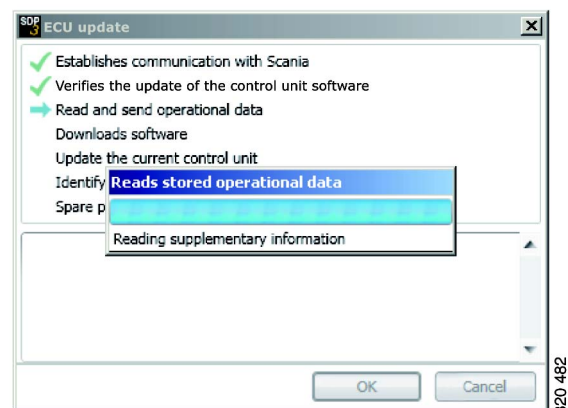

Updating software in the control unit



IMPORTANT!

Carry out the following checks before updating in order to avoid damage to the control unit which then may need to be renewed.

- that the vehicle has power
- that the computer is connected to mains voltage
- that the VCI is connected correctly to the vehicle.

Once the download is complete a new window is opened.

- 1 Read through the text and follow the instructions, see figure 8. Click on *OK* to start the update of the control unit.
- 2 The control unit is updated. The update takes a few minutes, see figure 9.

Figure 8

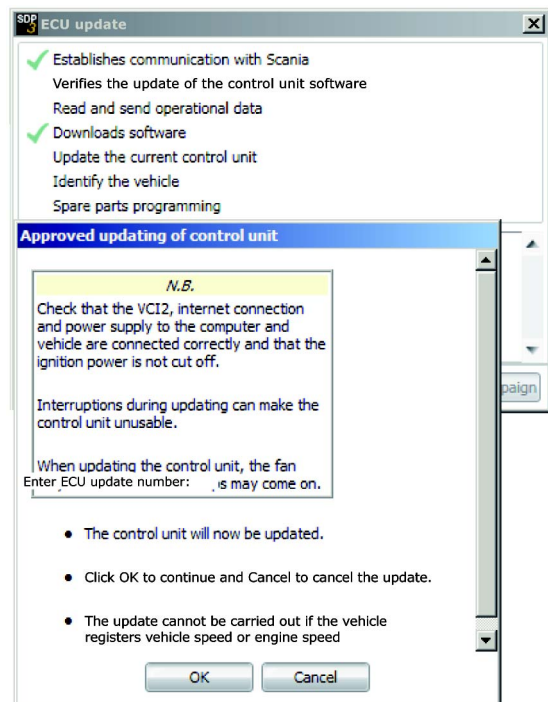

320 478

Figure 9

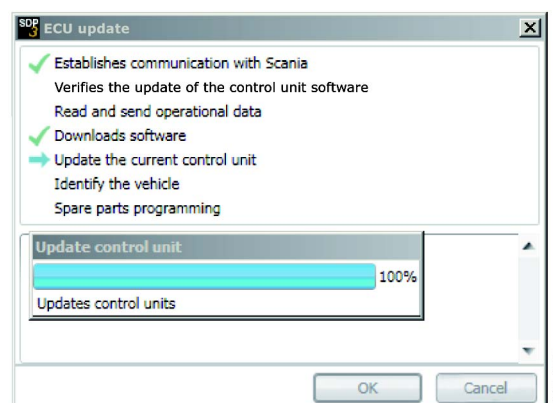

320 479

**IMPORTANT!**

If the update of the control unit is cancelled:

- Save a screen shot from the time the error occurred.
- Save the log files. Normally, these can be found in the folder *Logfiles (SDP3)* on the desktop.

Examples of log files are:

- *ApplicationLog.txt*
- *DataLinkLog.txt*
- *SDP3Tool.log*
- *TransportLog.txt*

It is important to save the log files at the exact time the fault occurred.

- Exit SDP3 and disconnect the power to the vehicle by switching off the starter key. Then turn the starter key to the drive position and start SDP3 again. Click on the ECU update button and make a new attempt to update the control unit software.

If the second attempt also fails, save a new screen shot. Create a fault report and attach all log files and screen shots together with operational data.

The file containing operational data has the chassis serial number as part of its file name. See the example below.

YS2P4X20092047668 2009-08-18 kl
1754.txt

- 3 The update continues with an update of the SOPS file and with spare part programming of the control unit, see figure 10.

Figure 10

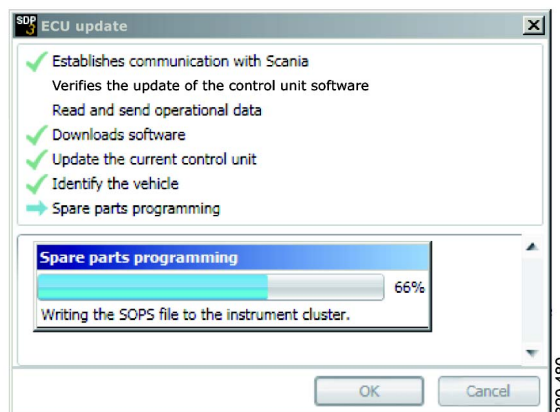

- 4 When the spare parts programming is complete a new window opens, see figure 11. The instructions in the window correspond to the instructions below and under the heading *Finishing work*. Close the window by clicking on *OK*.
- 5 Turn off the power on the vehicle by switching off the starter key.
- 6 Wait 30 seconds.
- 7 Turn the starter key to the drive position.

Figure 11

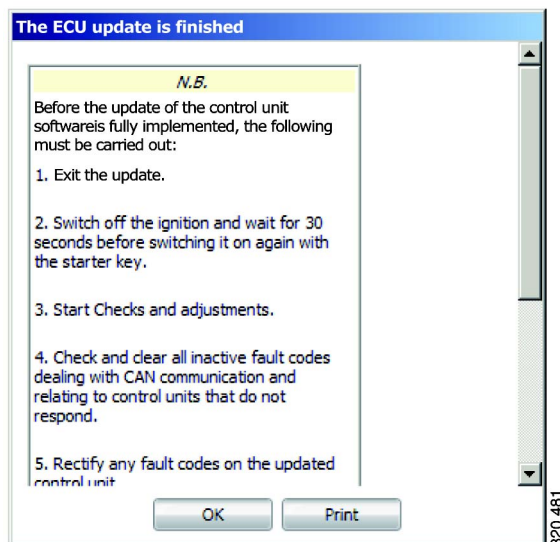

Finishing work

- 1 Clear all inactive fault codes regarding problems with the CAN communication or control units that do not respond.
- 2 Check whether there are any remaining fault codes in the control unit. If there are any fault codes they must be rectified before test driving the vehicle.
- 3 Highlight the control unit in SDP3. Figure 12 shows an example. Check that the control unit part number is one of the new numbers listed in the ECU update information.

Figure 12

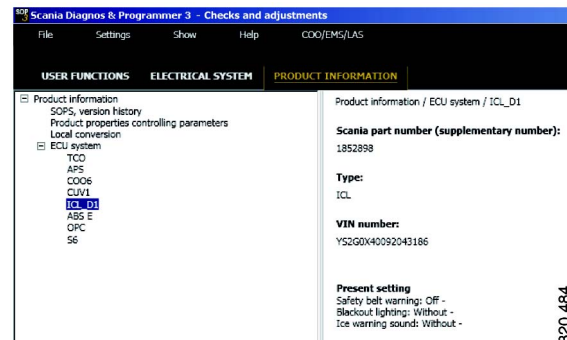

320 484

- 4 Test drive the vehicle.
- 5 Check if any new fault codes have been generated and rectify these if this is the case. After this the software update is complete.

Bodywork

The Bodywork work option provides access to the restricted parts of the program required to fit the bodywork to the vehicle.

The control function is fully accessible, while the adjustment function is limited according to the needs of the bodybuilder.

Connecting

General

Note: In order for SDP3 to be able to communicate with certain control units, the systems must be activated. This applies to the auxiliary heater and radio, which must be turned on when connecting.

The response time of individual control units varies after the starter voltage has been switched on. If SDP3 starts the control unit identification too soon after the starter voltage has been switched on, some control units may not respond. In that case, re-establish the connection.

SDP3 carries out a number of checks when connecting to the vehicle or industrial and marine engine. During the connection phase you will be given information about the activities being carried out by SDP3. If a fault occurs during the connection, you will be informed about this and guided through with the help of the program.

SDP3 reads and compares, for example, the information in the SOPS file with the information available in the control units. If there are discrepancies you will be informed about this, and if spare parts programming needs to be carried out on one or more control units, SDP3 will provide this option.

Procedure when connecting

The basic procedure when connecting to a vehicle is displayed here. With some types of work the procedure only includes parts of the steps below.

- SDP3 connects to the vehicle.
- SDP3 retrieves vehicle information from the vehicle.
- SDP3 identifies the vehicle's control units.

If any control unit fails to respond, this will be indicated at the bottom of the connection window.

- SDP3 reads the SOPS from the coordinator and instrument cluster which are the control units containing SOPS.
- SDP3 verifies SOPS. This means that the program checks both SOPS strings and checks that they are the same.

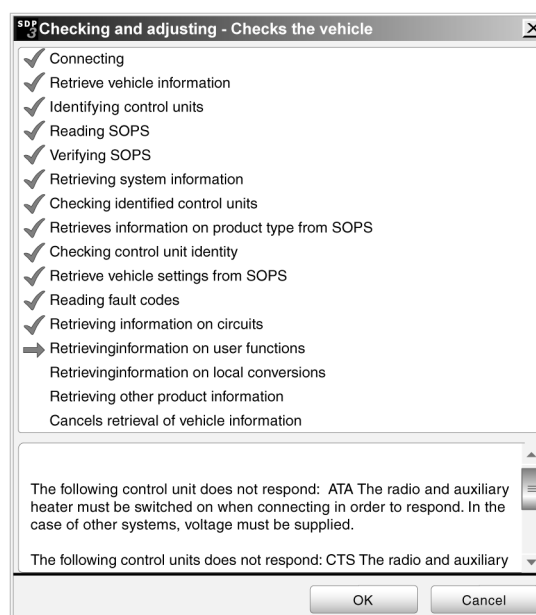

313 482

- SDP3 retrieves system information about the control units from its database.
- SDP3 checks identified control units against SOPS.

If one of the control units does not correspond to SOPS, you will be informed about this and about how to proceed.

- SDP3 retrieves information about the product type from SOPS. This means that SDP3 checks whether it is connected to a truck, bus or industrial and marine engine.
- SDP3 checks the identity of the control units.
- SDP3 retrieves the vehicle settings from SOPS.

SDP3 compares the control unit configuration with the contents of SOPS.

If the configuration differs, you will have the opportunity to carry out spare parts programming of the control units which are not configured correctly.

- SDP3 reads fault codes from the control units.
- SDP3 retrieves other information about the vehicle from its database.
- SDP3 finishes retrieving vehicle information and the OK button becomes available.

Spare parts programming

If the control unit configuration does not correspond to the contents of SOPS (which can be due to one of the control units being replaced), SDP3 will propose spare parts programming.

During spare parts programming the parameters in the control unit are changed to correspond to the content in SOPS.

If you are asked whether you wish to carry out spare parts programming on one or more control units, you need to be sure that it is necessary before you answer yes. Otherwise you should refrain from carrying out spare parts programming.

If you choose to carry out spare parts programming on a control unit, SDP3 will guide you through the entire procedure.

After renewing one or more control units, SDP3 should always be connected in order to carry out spare parts programming before the work is finished.

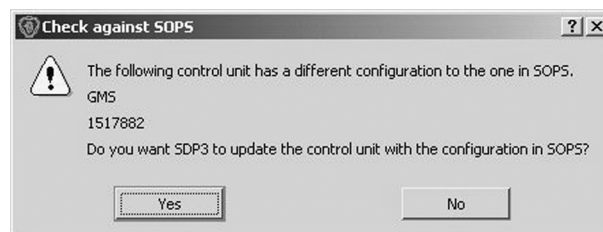

When the control unit configuration differs from SOPS, SDP3 suggests spare parts programming.

Communication

Information is constantly being exchanged between SDP3 and the control units in the vehicle/engine SDP3 is connected to. Signals and messages are sent in both directions.

Unexpected interference in communication can occur which affects the ability to, for example, read and display information from the control units.

When interference in communication occurs, you will be informed of this, either in the form of a fault message or via a symbol.

It may be worth knowing that disruptions to communication which occur after you have connected the program and started work are usually temporary. Where the fault message indicates a cause, check what is indicated and try again. If no cause is given, try again several times to see whether the communication problems disappear. If the fault does not seem to affect the work you are doing, you can ignore the fault message and continue.

Fault handling in the program is being continuously improved.

The document entitled Communication problems, which can be accessed from the Help menu, provides more detailed information about disruptions to communication.

Graphic symbols in the program

Explanations of the graphic symbols used in the program are provided below.

Some symbols may be combined to display more than one state.

Navigation tree



The control unit does not respond.



The control unit responds but the information does not exist in SOPS. Control units may have been fitted and not programmed correctly.



The configuration in the control unit differs from the configuration in SOPS.



The VIN or engine number in the control unit differs from the VIN or engine number in SOPS.



The control unit responds but there is no support for it in SDP3. There is either no support at all for the assembly part number or there is no support for the assembly part number combined with the vehicle or I/M engine configuration.



The control unit responds, but has incomplete software.



There are fault codes associated with the system or user function.



The program did not find a SOPS file.



The control unit has been manipulated.

Status field



A valid USB key is connected.



No valid USB key is connected.



No contact between VCI and vehicle or I/M engine.



No contact between computer and VCI.



Contact between computer, VCI and vehicle or I/M engine but communication not working.



Communication between computer and vehicle or I/M engine is working.



SDP3 is in contact with a local network.



SDP3 is not in contact with any local network.



Air pressure for brake circuit 1.



Air pressure for brake circuit 2.



Normal battery voltage, more than 24.5 V.



Low battery voltage, between 22.0 and 24.5 V. The system is working but the battery charger should be connected.



Incorrect battery voltage, less than 22 V. The system is not working and the battery charger must be connected.



The vehicle odometer reading. For I/M engines the operational time is shown.

Fault codes



Fault code.



Primary or secondary fault code.



The fault code was registered as active when fault codes were last read.



Number of times a fault code has been registered as active.



Vehicle system time at which the fault code was last registered as active.

Read/activate

A

The control unit recognises an activity (input signal, output signal or communication).



The control unit detects that a received value (of a signal or a message) is outside the expected range.

?

Communication works well but the control unit does not recognise the value received. The symbol is also displayed for components which are not valid for the vehicle or if no calibration has been carried out.



Interference in communication between the control unit and SDP3.

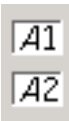

The control unit recognises an activity (input signal, output signal or communication) for a given function.

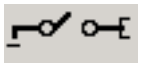

The circuit to the control unit input is open (not closed to ground).

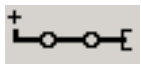

The circuit to the control unit input is closed (to + 24 V).

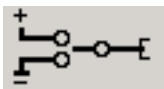

The circuit to the control unit input is open (not closed to ground or to + 24 V).

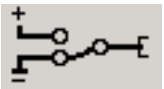

The circuit to the control unit is closed (to ground).

Demo mode

The USB key must be connected in order to run the program in demo mode. VCI does not need to be connected.

Starting and exiting demo mode

Demo mode can be found under File in the menu. When you start demo mode, you have the option of selecting from a number of demo vehicles which have been included.

If you have saved information from your own vehicles, navigate to the folder where the files are saved and select the file you wish to use from there.

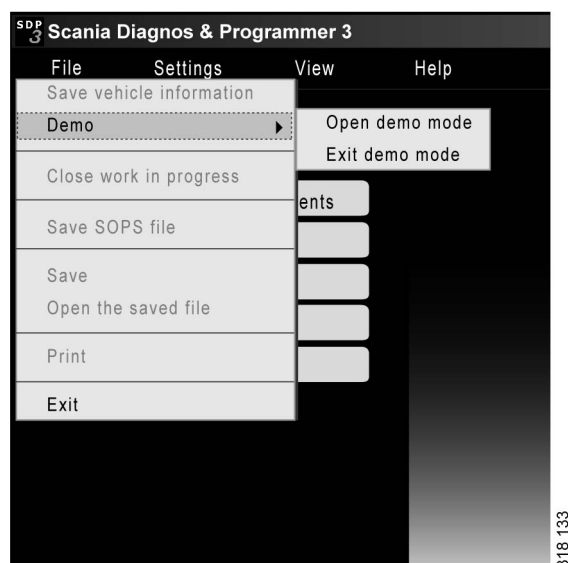

Demo mode is started and stopped from File.

This is how demo mode works

The information displayed in demo mode has been provided by real vehicles and has been recorded and saved in the program.

The program works in the same way as it would if it was connected to a vehicle. The program "does not know" that it is running in demo mode. The saved information represents the program's communication with the vehicle control units.

If you choose to do something which means that the program is expecting more information than is available in the saved vehicle information, the program will interpret this as an interruption of communication with a control unit.

An example of this is when the program sends a new value to a control unit and expects to receive a modified value back.

SDP3 will then think that contact has been lost with the control unit and will work as it would during normal fault handling.

Saving and printing vehicle information

You can save selected information from the connected vehicle and store it in any folder on the computer. Access the File menu and select from:

1 Save vehicle information

When you select this option a large amount of data from the vehicle is automatically saved in a text file, regardless of the task in progress. You can then use the saved file to view the vehicle in demo mode. You can save vehicle information once per connection.

2 Save SOPS file

The vehicle's current SOPS file can be read and saved here.

3 Save

If you place yourself at circuit level in the navigation tree and select Save, the selected information is saved in a PDF file. A window opens in which you can tick those parts of the work in progress you wish to save. Both illustrations and text are saved in the PDF file.

4 Open the saved file

Open the saved files stored in any folder here.

5 Print

This option allows you to first open your saved file and then print it out. When you select Print, a PDF file is first created with your selected information which is then printed immediately on the selected printer.

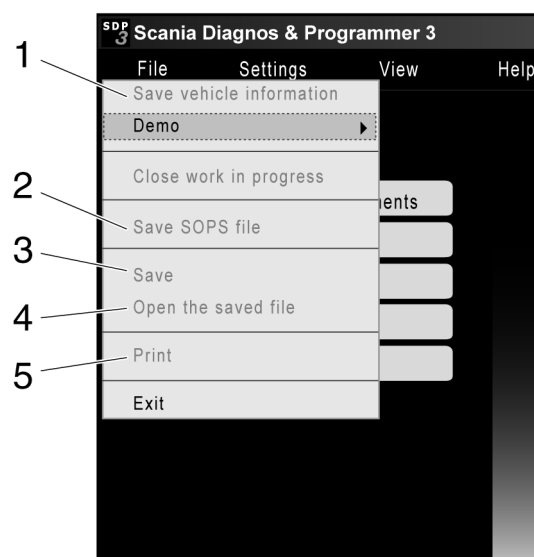

You can save and print vehicle information via the File menu.

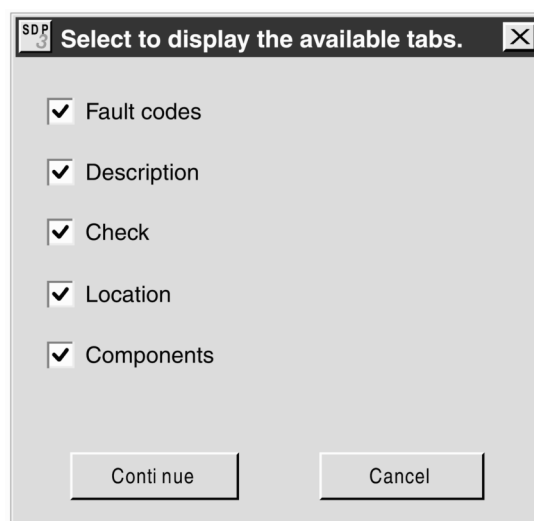

When you choose to save or print, tick the parts of the current information you wish to add to the PDF file which is automatically created.

Viewing stored operational data

It is possible to view stored operational data when you are connected to the vehicle.

There is also an option here to save the file with vehicle data. The file that is saved contains the same information as that saved from the Save vehicle information menu option. The file can be used to view the operational data later via the SVAP home page or to view the vehicle in demo mode.

When you access and view stored operational data the file will be sent to Scania. Experience from real operating conditions is an important aid to the development of engines and the diagnostics program.

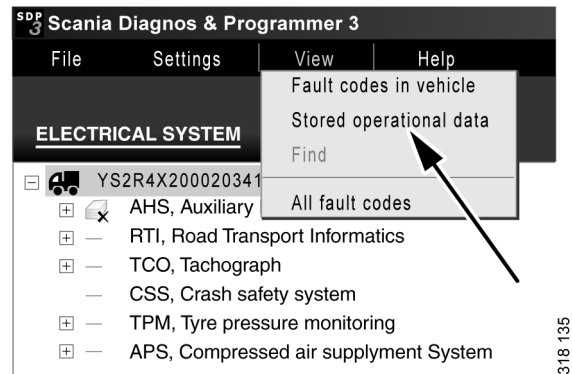

Stored operational data can be found under View.

To view stored operational data, use SDP3 to access the SVAP website. It is therefore necessary for the computer to have a network connection to Scania.

You need to have a certificate for your computer and belong to the VERA_user group in order to access stored operational data. You can find out how to obtain a certificate and how it operates from the Service Development website under Workshop Tools & Equipment. You can access the website via SAIL.

Proceed as follows to analyse and send stored operational data:

- 1 Select Stored operational data under View in the menu.
- 2 Log in using your SAIL identity in the login dialogue which is displayed.
- 3 Then follow the instructions given in the program.

Search

Select Find under View in the menu to access the SDP3 search function.

Select the category and search conditions by pressing the arrow on the right of the relevant box in the search window. Then press the Search button. The categories that you can search on are:

- **Fault code:** Optional search conditions are system family and fault code heading. The full description of the fault code is displayed first, followed by clickable links to the circuits and user functions affected by the fault code. All fault codes can be searched, regardless of whether they are active or not.
- **Component:** Optional search conditions are component family and component code. The search has given hits on the circuits and user functions where a selected component is fitted. The hits are displayed as clickable links.
- **Cable marking:** Optional search conditions are system family and serial number in cable marking. The search has given hits on the circuits and user functions where a selected cable is fitted. The hits are displayed as clickable links.

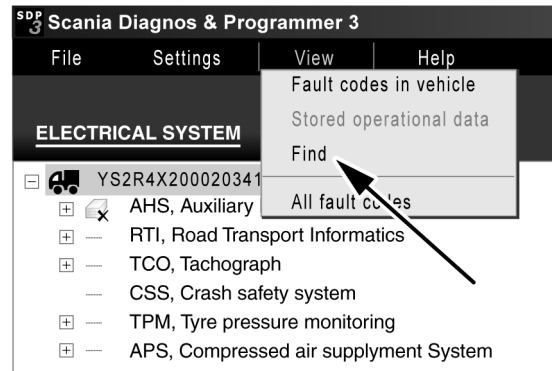

318 136

The search function can be found under View in the menu.

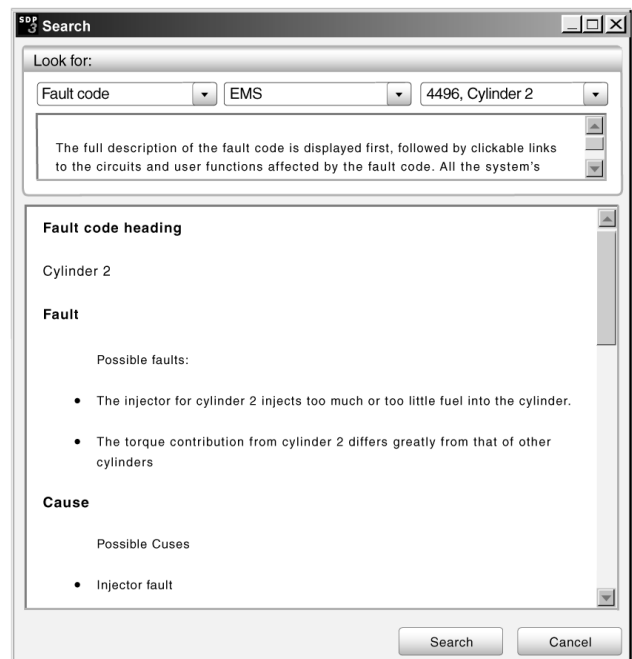

Viewing all fault codes

SDP3 can also display fault codes that have not been generated. Go to the View menu:

- Select All fault codes if you want to see all the fault codes that can be generated, whatever the vehicle. SDP3 does not need to be connected to the vehicle or VCI.

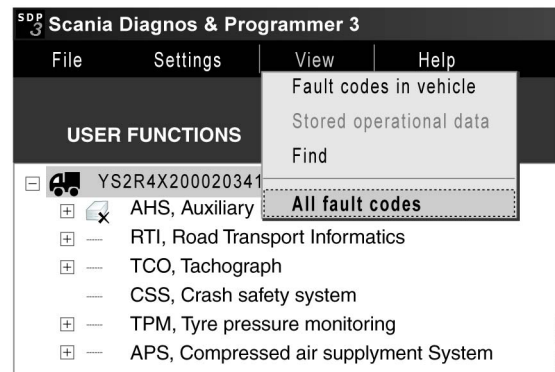

316 137

- If SDP3 is connected, you can select the option Fault codes in vehicle. This displays all the fault codes that can be generated in the vehicle concerned.

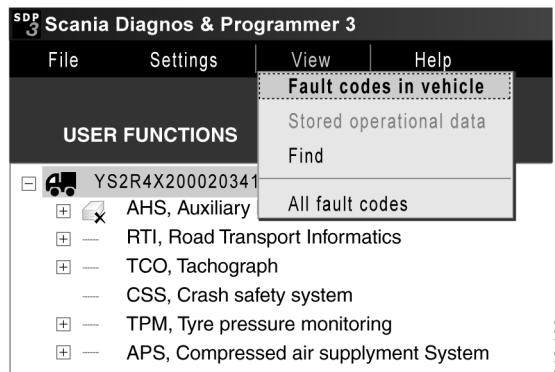

318 138

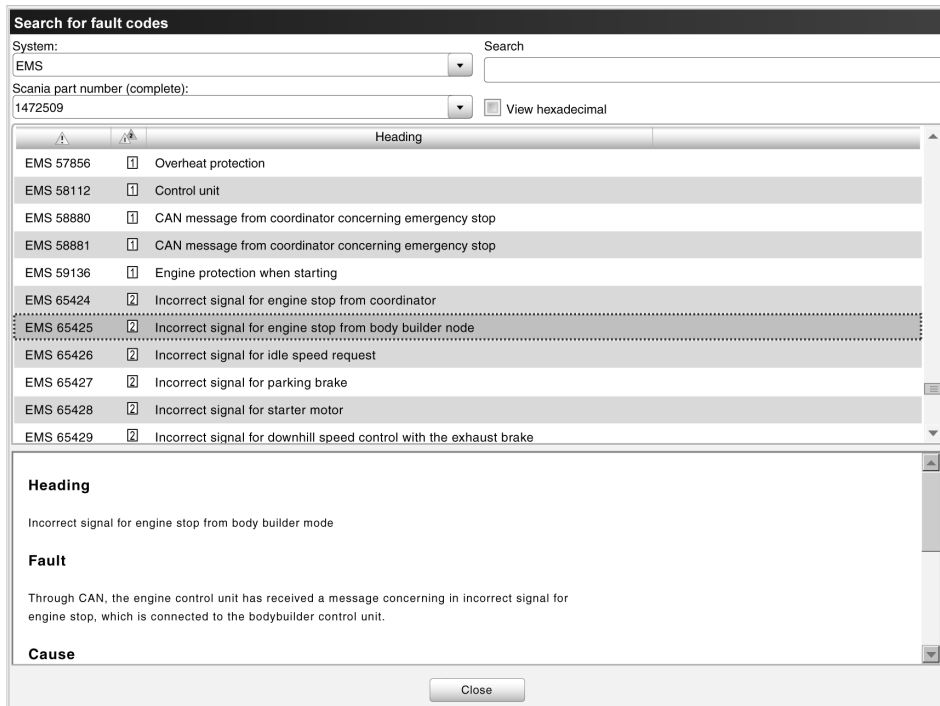

313 498

You can search for fault codes by system and by control unit assembly part number. You can also search for individual fault codes via the fault code number. A separate window opens which remains available while you work on other activities in SDP3.

Help

You can obtain information on SDP3 by looking at a number of help documents. The help documents are found under the Help menu.

The following help documents are available:

- 1 User instructions: description of how to use SDP3.
- 2 Release notes: descriptions of what is new in the latest version of SDP3.
- 3 View supported assembly part numbers: a list of which control units SDP3 supports.
- 4 Communication problems: describes how to troubleshoot a communication problem between SDP3 and the control units.
- 5 Fault reporting: a description of how to report faults in SDP3.
- 6 About SDP3: general version information about SDP3.

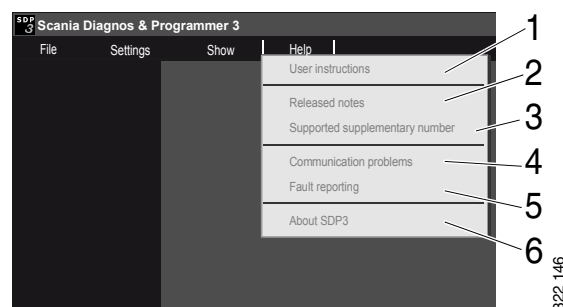

Fault handling

Electromagnetic fields

Scania VCI and most of the computers on the market are protected against the electromagnetic fields which are generated by all electrical equipment.

However, this protection is limited and is not always sufficient to allow uninterrupted communication. Take care when using the programs close to the following equipment:

- Mobile phones and transmitters
- Electric welders
- Power supply installations, e.g. thyristor units

Reporting faults and queries

It may be necessary to ask questions and receive help with the programs.

Dealers should contact the distributor with any questions and suggestions for program development. The distributor should consult the factory in Södertälje, Sweden.

If any faults or "bugs" are detected in Scania software, this should be reported to the factory. Do this by contacting your distributor, who will report this through the normal reporting system. Reports about faults help Scania make adjustments to future versions and improve the program.